



HBLED Driver for High Current Applications

General Description

The VAS1210P is a step-down constant-current high-brightness LED (HBLED) drivers provide a cost-effective solution for exterior lighting, architectural and ambient lighting, LED bulbs such as MR16 and other LED illumination applications.

The device operates from a 7V to 60V input range. The device drivers an external NMOS and can provide an externally adjustable output current up to 5A.

The device is well suited for applications requiring a wide input voltage range. The high-side current-sensing and an integrated current setting circuitry minimize the number of external components while delivering an LED current with $\pm 5\%$ accuracy. A novel control algorithm ensures excellent input-supply rejection and fast response during load transients and PWM dimming. The devices operate up to 1MHz switching frequency, thus allowing for small component size.

The device operate over the -40°C to $+85^{\circ}\text{C}$ temperature range and available in SOT23-6L.

Application

- Architectural, Industrial and Ambient Lighting
- MR16 and Other LED Bulbs
- Emergency Lighting

Typical Application Circuit

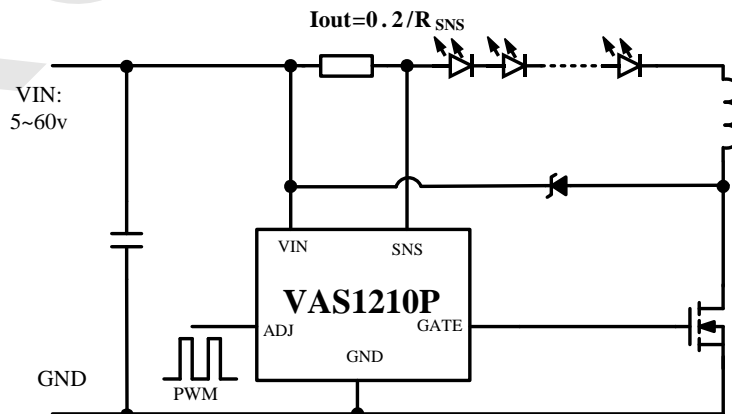

Features

- Wide supply range from 5V to hundreds of volts
- High-Side Current Sense
- PWM Dimming
- 20kHz Maximum PWM Dimming Frequency
- No Compensation Capacitor
- Up to 1MHz Switching Frequency
- $\pm 5\%$ LED Current Accuracy
- Adjustable Constant LED Current
- -40°C to $+85^{\circ}\text{C}$ Operating Temperature Range

Ordering Information

Order Number	Package Type	Temp. Range
VAS1210PIC06E	SOT23-6L	-40°C to 85°C

I: Industry, $-40\sim 85^{\circ}\text{C}$
06: Pin Number

C: SOT
E: ROHS

Pin Configuration

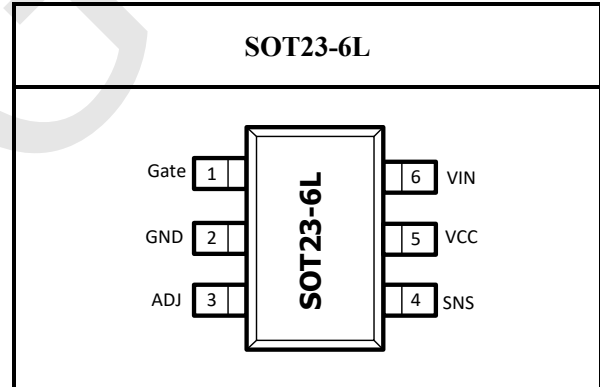



Block Diagram

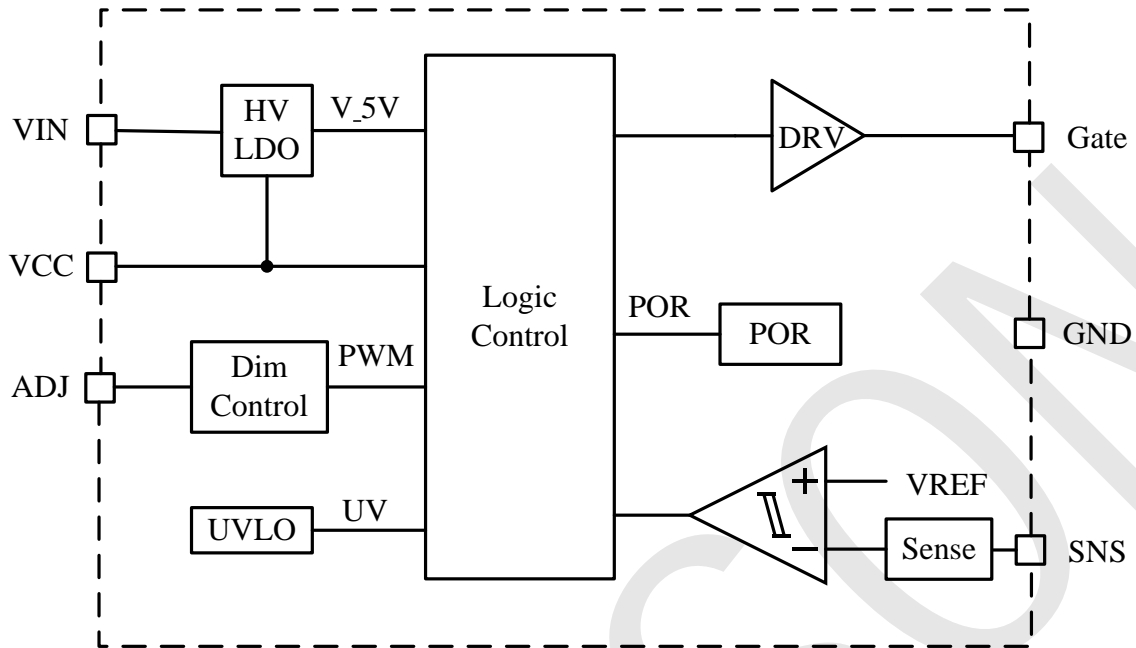

PIN Description

PIN NO.	Name	Description
1	Gate	Gate Drive Output. Connect to the gate of an external N-MOSFET
2	GND	Ground
3	ADJ	PWM signal input
4	SNS	Current Sense Input
5	VCC	5V Voltage Regulator Output. Connect a 1μF capacitor from VCC to GND
6	VIN	Positive Supply Voltage Input. Bypass with a 1μF or higher value capacitor to GND

Absolute Maximum Ratings^(Note1)

Parameters	Maximum Ratings
VIN, SNS to GND	-0.3V to 66V
VIN to SNS	-0.3V to +0.3V
ADJ, VCC, Gate to GND	-0.3V to 8V
Operating temperature range	-40°C to +85°C
Junction temperature	-40°C to +150°C
Storage temperature range	-65°C to +150°C
ESD human body model	2000V

Note 1: Absolute Maximum Ratings indicate limits beyond which damage to the device may occur. Operating Ratings indicate conditions for which the device is functional, but do not guarantee specific performance limits. Electrical Characteristics state DC and AC electrical specifications under particular test conditions which guarantee specific performance limits. This assumes that the device is within the Operating Ratings. Specifications are not guaranteed for parameters where no limit is given, however, the typical value is a good indication of device performance.



Electrical Characteristics

Typical case^(Note2): VCC=12V, T_A=25°C(unless otherwise specified)

Symbol	Parameter	Condition	spec			Unit
			Min.	Typ.	Max.	
V _{IN}	Input voltage range		7		60	V
I _{CC}	Quiescent current	ADJ floating, all external devices open		5000	1000	μA
SENSE COMPARATOR						
V _{SNS}	Mean current sense threshold voltage(defines LED current setting accuracy)	Measured on SNS pin with respect to VIN, ADJ pin floating	190	200	210	mV
V _{SNS_HYS}	Sense threshold hysteresis			±10%		
I _{SNS}	Current Sense Input Current	V _{IN} -V _{SNS} =200mV		5		μA
T _{PD}	Internal comparator Propagation Delay			50		ns
DIMMING INPUT						
F _{PWM}	PWM dimming range		100		20,000	Hz
V _{IH}	PWM Dimming Input-Voltage-High		2.5			V
V _{IL}	PWM Dimming Input-Voltage-Low				0.5	V
GATE DRIVER						
I _{Gate-SRC}	Gate Driver Source Current	V _{SNS} = V _{IN} , V _{Gate} = 0		400		mA
I _{Gate-SINK}	Gate Driver Sink Current	V _{SNS} = V _{IN} - 220mV, V _{Gate} = 5V		400		mA
VCC REGULATOR						
VCC	Regulator Output Voltage			6		V

Note 2: Production testing of the device is performed at 25°C. Functional operation of the device and parameters specified over other temperature range, are guaranteed by design, characterization and process control.



Typical Performance Characteristics

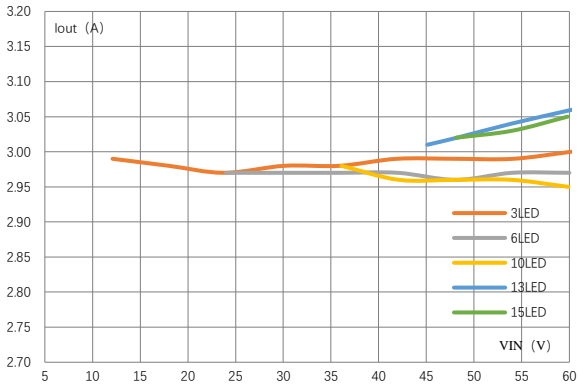

Vin vs. Iout

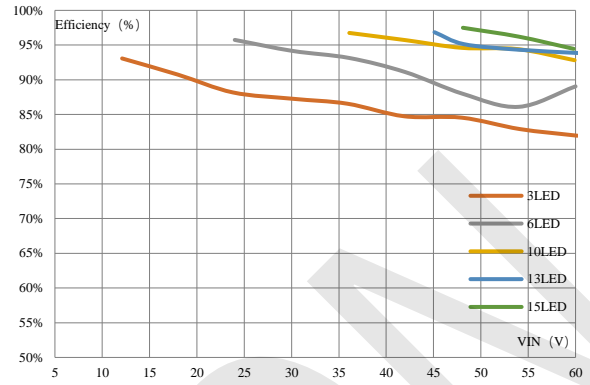

Vin vs. Iout

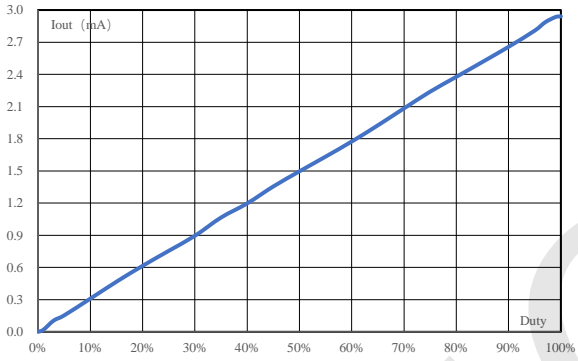

PWM vs. Iout



Typical Performance Waveforms

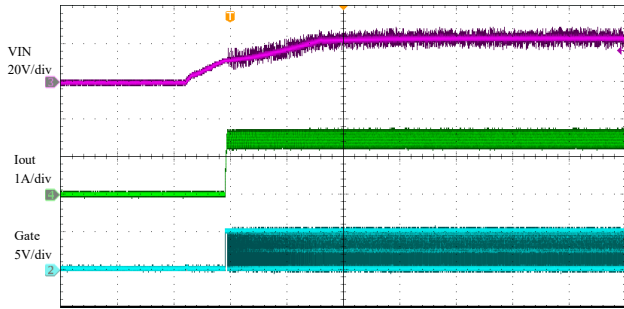

Power Up

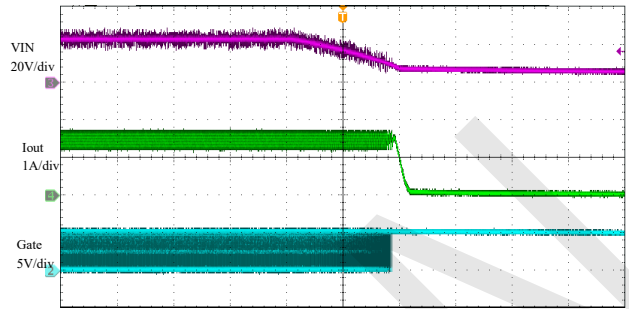

Power down

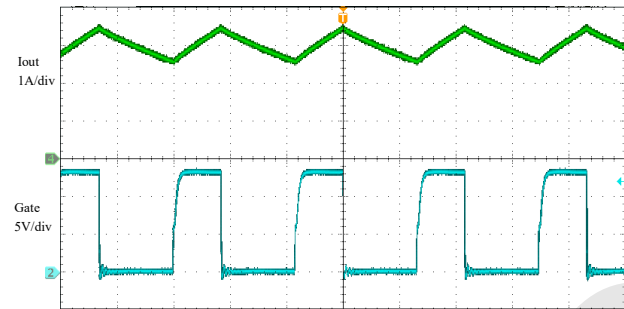

LED Hot Removed

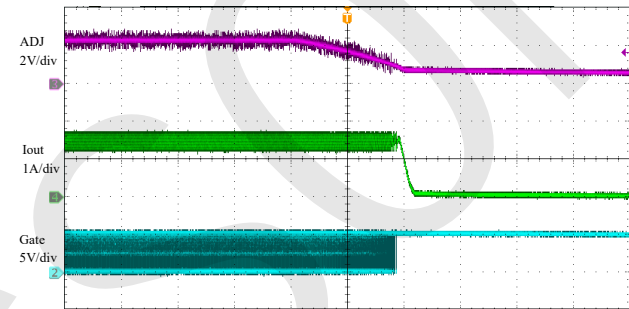

LED Hot Plug-in

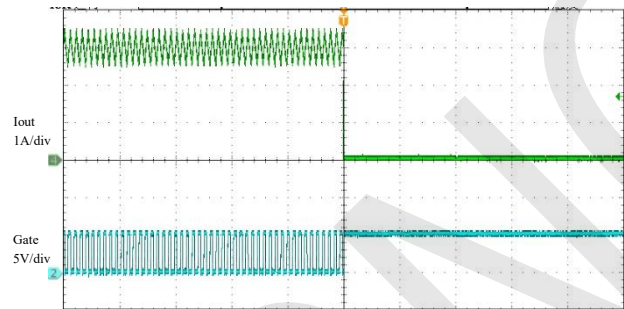

LED Short Protection

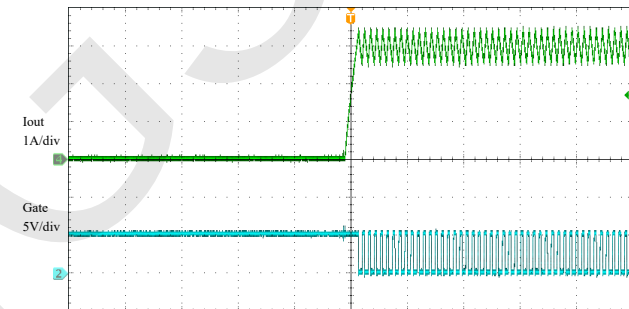

Short LED Recovery

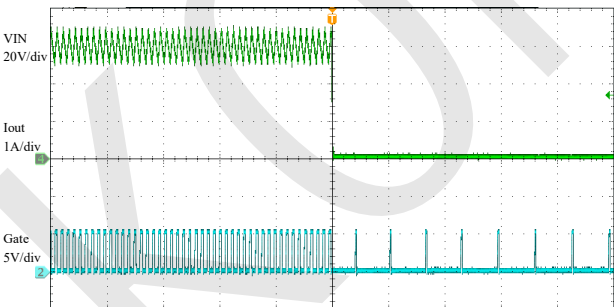

LED Short Protection

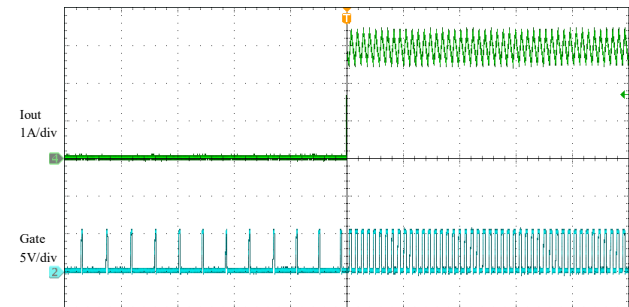

Short LED Recovery



Application Information

The VAS1210P is a step-down, constant-current, high-brightness LED(HBLED) driver. These devices operate from a 7V to 60V input voltage range and provide up to 0.4A of source and sink drive capability to the gate of an external MOSFET. A high-side current-sense resistor sets the output current. ADJ allows for 100Hz~20KHz PWM signal dimming.

The high-side current-sense scheme and on-board current setting circuitry minimize the number of external components while delivering LED current with a $\pm 5\%$ accuracy, using a 1% sense resistor.

1. 5V Regulator

VCC is the output of a 5V regulator. Bypass VCC to GND with a 1uF capacitor to enhance the capability to drive external NMOS.

2. Selecting R_{SNS} to Set the LED Current

The VAS1210P feature a programmable LED current using a resistor connected between VIN and SNS. Use the following equation to calculate the sense resistor:

$$R_{SNS} = \frac{0.2}{I_{LED}}$$

The table below gives values of nominal average output current for several values of current setting resistors (R_{SNS}) in the typical application circuit shown on page 1.

R_{SNS} (Ω)	nominal average output current(A)
1	0.2
0.33	0.67
0.1	2

3. Current Regulator Operations

The VAS1210P regulate the LED output current using an input comparator with hysteresis (Show in the figure bellow).

As the current through the inductor ramps up and the voltage across the sense resistor reaches the upper threshold, the voltage at Gate goes low, turning off the external MOSFET. The MOSFET turns on again when the inductor current ramps down through the freewheeling diode until the voltage across the sense resistor equals the lower threshold. Use the following equation to determine the operating frequency:

$$F_{SW} = \frac{(V_{IN} - V_{OUT}) \times V_{OUT}}{V_{IN} \times \Delta I \times L}$$

Where ΔI is the coil peak-peak ripple

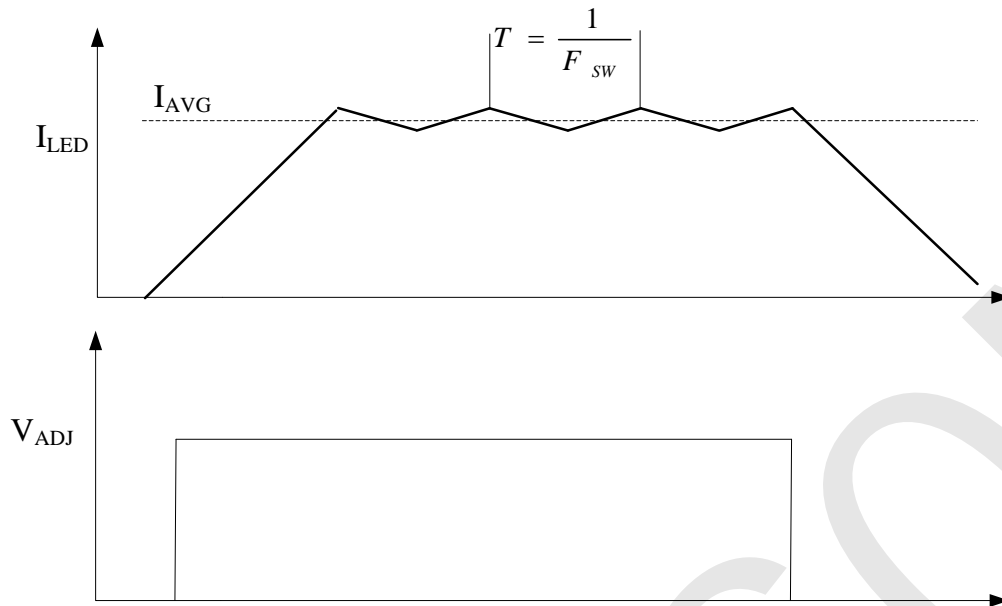

4. Inductor selection

Recommended inductor values for the VAS1210P are in the range 47μH to 470μH.

Higher values of inductance are recommended at higher supply voltages and low output current in order to minimize errors due to switching delays, which result in increased ripple and lower efficiency. Higher values of inductance also result in a smaller change in output current over the supply voltage range. The inductor should be mounted as close to the chip as possible with low resistance connections to the V_{IN} pins and the drain of NMOS. The chosen coil should have a saturation current higher than the peak output current and a continuous current rating above the required mean output current. It is recommended to use inductor with saturation current bigger than 3A for 2A output current and inductor with saturation current bigger than 500mA for 350mA output current. The inductor value should be chosen to maintain operation duty cycle and switch 'on/off' times within the specified limits over the supply voltage and load current range. Following information can be used as a guide.

GATE Switch 'on' time:

$$T_{ON} = \frac{L \times \Delta I}{V_{IN} - V_{LED} - I_{AVG} (R_S + R_L + R_{DS(ON)})}$$

Note that : T_{ON}>200ns

GATE Switch 'off' time:

$$T_{OFF} = \frac{L \times \Delta I}{V_{LED} + V_D + I_{AVG} (R_S + R_L)}$$

Note that : T_{OFF}>200ns

Where:

L is the coil inductor (H)

R_L is the resistance (Ω)

I_{AVG} is the required LED current (A)

ΔI is the coil peak-peak ripple current (A) (internally set to 0.2×I_{AVG})



V_{IN} is the supply voltage (V)

V_{LED} is the total LED forward voltage (V)

R_{RDSON} is the switch resistor of NMOS (Ω)

V_D is the diode forward voltage at the required load current (V)

Example:

For $V_{IN}=12V$, $L=330\mu H$, $R_S=0.67\Omega$, $R_L=0.64\Omega$, $R_{DSON}=0.05\Omega$, $I_{AVG}=333mA$ and $V_D=0.36V$

$$T_{ON} = \frac{(330 \times 10^{-6} \times 0.067)}{(12 - 3.4 - 0.453)} = 2.71 \mu s$$

$$T_{OFF} = \frac{(330 \times 10^{-6} \times 0.067)}{(3.4 + 0.36 + 0.436)} = 5.27 \mu s$$

This gives an operating frequency of 125.3 kHz and a duty circle of 0.34.

5. LED Current Ripple

The LED current ripple is equal to the inductor current ripple. In cases when a lower LED current ripple is needed, a capacitor can be placed across the LED terminals.

6. Capacitor selection

A low ESR capacitor should be used for input decoupling, as the ESR of this capacitor appears in series with the supply source impedance and lowers overall efficiency. This capacitor has to supply the relatively high peak current to the coil and smooth the current ripple on the supply.

If the source is DC supply, the capacitor is decided by the ripple of the source, the value is given by:

$$C_{min} = \frac{I_{OUT} \times T_{ON}}{\Delta U_{max}}$$

$I_{R_{OUT}}$ is the value of output current, ΔU_{max} is the ripple of power supply. T_{ON} is the 'ON' time of MOSFET. The value is normally 2 times of the minimum value. Recommend a 100 μF capacitor or larger.

7. MOSFET Selection

The VAS1210P's gate driver is capable of sourcing 0.1A and sinking 0.2A of current. MOSFET selection is based on the maximum input operating voltage V_{IN} , output current I_{LED} , and operating switching frequency. Choose a MOSFET that has a higher breakdown voltage than the maximum operation voltage, low $R_{DS(ON)}$, and low total charge for better efficiency. MOSFET threshold voltage must be adequate if operated at the low end of the input-voltage operating range.

8. Schottky Diode Selection

The Schottky diode breakdown voltage should high enough to withstand the maximum operating voltage and its forward current rating must be higher than the maximum LED current.

9. PCB Layout

Careful PCB layout is critical to achieve low switching losses and stable operation. Use a multilayer board whenever possible for better noise immunity. Minimize ground noise by connecting high-current ground returns, the input bypass-capacitor ground lead, and the output-filter ground lead to a single point (star ground configuration). In normal operation, there are two power loops. One is formed when the MOSFET is on and the high current flows through $V_{IN}-R_{SNS}-LEDs-Inductor-MOSFET-GND$. The other loop is formed when the MOSFET is off when the high current circulates through $R_{SNS}-LEDs-Inductor-Schottky\ diode$. To minimize noise interaction, each loop area should be as small as possible.

Place R_{SNS} as close as possible to the input filter and V_{IN} . For better noise immunity, a Kelvin connection is strongly recommended between SNS and R_{SNS} .



Package Information (SOT23-6L)

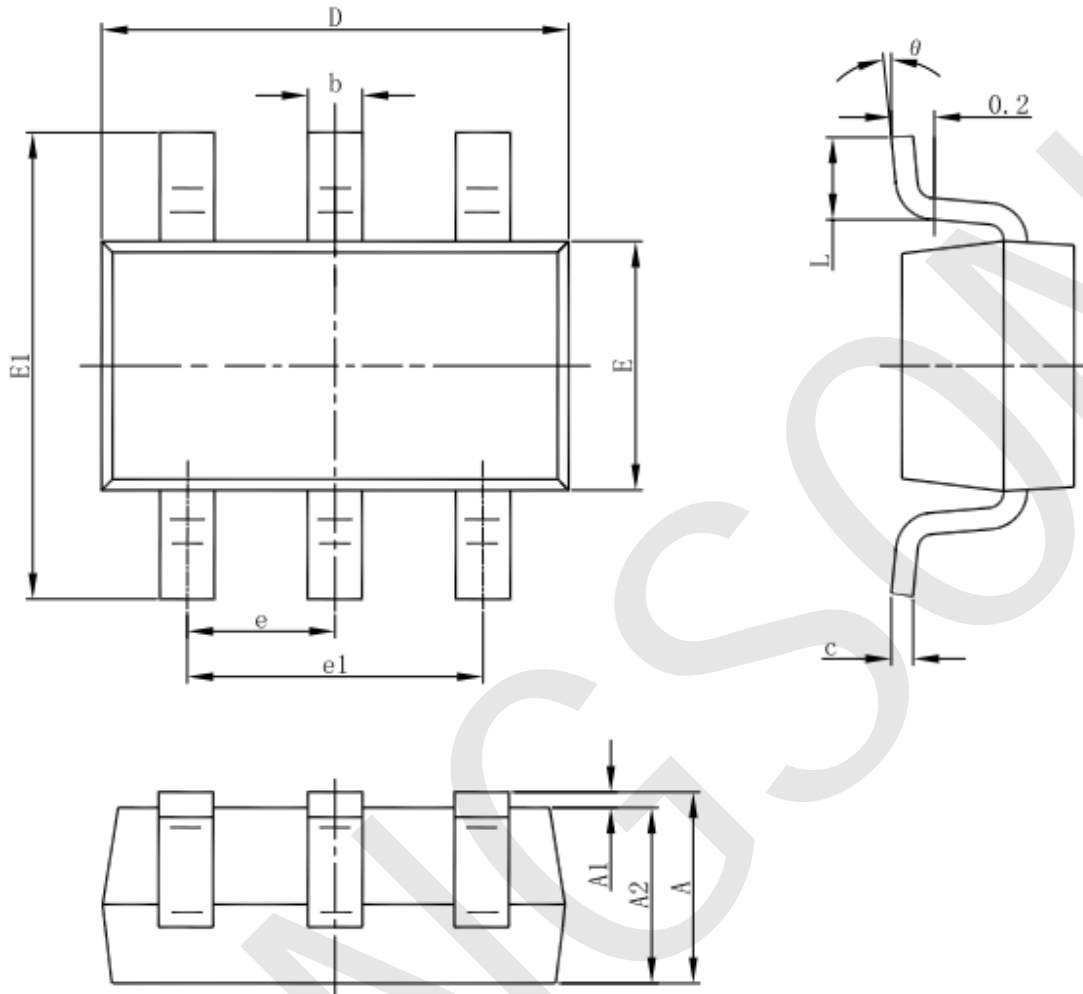

Symbol	Dimensions In Millimeters		Dimensions In Inches	
	Min	Max	Min	Max
A	1.050	1.250	0.041	0.049
A1	0.000	0.100	0.000	0.004
A2	1.050	1.150	0.041	0.045
b	0.300	0.500	0.012	0.020
c	0.100	0.200	0.004	0.008
D	2.820	3.020	0.111	0.119
E	1.500	1.700	0.059	0.067
E1	2.650	2.950	0.104	0.116
e	0.950(BSC)		0.037(BSC)	
e1	1.800	2.000	0.071	0.079
L	0.300	0.600	0.012	0.024
θ	0°	8°	0°	8°