



15A Synchronous Buck LED Driver

General Description

The VAS1220 is a constant current synchronous step-down controller for accurately regulating output current up to 15A; VAS1220 adopts a 50mV low voltage sense topology to minimize system power dissipation and provides an excellent solution for HB-LED drivers.

The device operates from a 7V to 60V input range and the average current-mode controller will maintain inductor current regulation over a wide output voltage of up to $(V_{IN}-2V)$. Its novel control algorithm ensures excellent input-supply rejection and fast response during load transients and PWM dimming.

The device integrates UVLO and thermal shutdown, and is available in TSSOP14.

Features

- Up to 15A output current, External NMOS
- Wide supply range from 7V to 60V
- Up to 97% efficiency
- 50mV Sense Voltage
- Excellent PWM dimming, 100000:1
- $\pm 5\%$ LED Current Accuracy
- -40°C to $+85^{\circ}\text{C}$ Operating Temperature Range

Typical Application Circuit

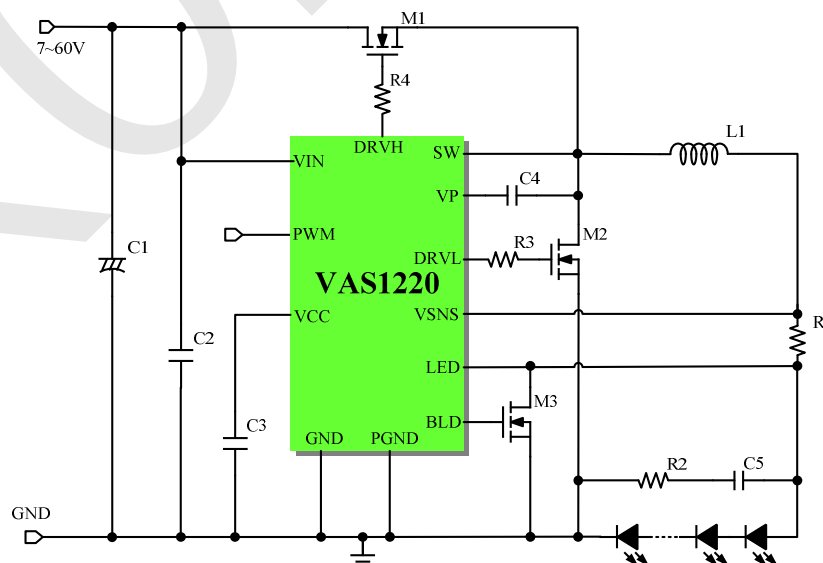

Application

- RGBW Stage lamp
- Other high current applications

Ordering Information

Order Number	Package Type	Temp. Range
VAS1220IM14E	TSSOP-14	-40°C to 85°C

I: Industry, $-40\sim 85^{\circ}\text{C}$
14 : Pin Number

M: TSSOP
E: ROHS

Pin Configuration

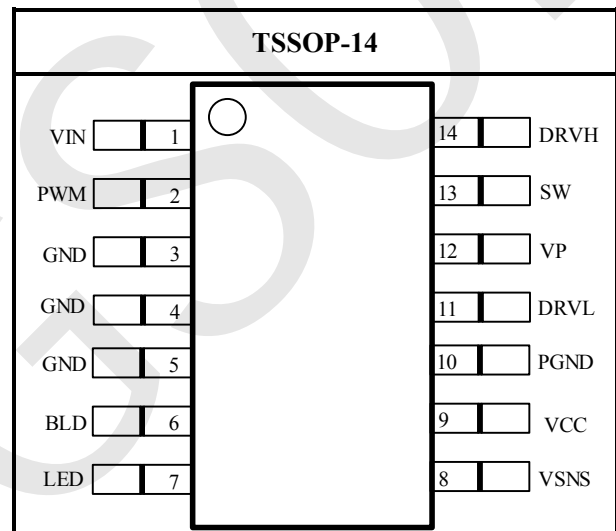



Pin Description

PIN NO.	Name	Description
1	VIN	Positive Supply Voltage Input. Bypass with a 1μF or higher value capacitor to GND
2	PWM	Drive with a PWM signal to adjust output current
3, 4, 5	GND	Analog ground
6	BLD	Output bleeder NMOS gate driver
7	LED	Connect to the anode of the LED string
8	VSNS	Current Sense Input, connect a resistor between LED and VSNS to set the output current $I_{LED} = 0.05 / R_{SNS}$
9	VCC	Internal power supply, connect a 1μF capacitor to GND
10	PGND	Power ground of the internal driver
11	DRVL	Low-side external NMOS gate drive output
12	VP	Boost-trap output pin, connect a 1μF capacitor to SW
13	SW	Switching node of the output Power MOS
14	DRVH	High-side external NMOS gate drive output

Absolute Maximum Ratings ^(Note1)

Parameters	Maximum Ratings
VIN, VSNS, LED, SW, DRVH, VP to GND	-0.3V to 66V
LED to VSNS	-0.3V to +0.3V
VCC, PWM, DRVL, BLD to GND	-0.3V to 8V
Power dissipation	500mW
Operating temperature range	-40°C to +85°C
Junction temperature	-40°C to +150°C
Storage temperature range	-65°C to +150°C
ESD human body model	2000V

Note 1: Absolute Maximum Ratings indicate limits beyond which damage to the device may occur. Operating Ratings indicate conditions for which the device is functional, but do not guarantee specific performance limits. Electrical Characteristics state DC and AC electrical specifications under particular test conditions which guarantee specific performance limits. This assumes that the device is within the Operating Ratings. Specifications are not guaranteed for parameters where no limit is given, however, the typical value is a good indication of device performance.



Electrical Characteristics

Typical case ^(Note2): $V_{IN}=12V$, $T_A=25^{\circ}C$ (unless otherwise specified)

Symbol	Parameter	Condition	Min	Typical	Max	Unit
V_{IN}	Input Voltage Range		7		60	V
V_{UVLO}	Under-voltage Lockout	V_{IN} ramping		4.5		V
$V_{UVLO-HY}$	UVLO hysteresis			0.2		V
VCC	Internal Power Supply Voltage			6		V
I_{CC}	Quiescent current	$V_{PWM}=0$		500		μA
V_{SNS}	Mean Current Sense Threshold Voltage(defines LED Current Setting Accuracy)	Measured on VSNS pin with respect to LED pin, PWM pin floating	47.5	50	52.5	mV
V_{SNS-HY}	Sense Threshold Hysteresis			$\pm 15\%$		
V_{IL_PWM}	PWM Dimming Logic Low				0.5	V
V_{IH_PWM}	PWM Dimming Logic High		2.5			V
R_{HS_DRV}	HS Gate Driver pull up resistance	$V_{IN}=12V$, $V_{SW}=11.8V$		0.9		Ω
	HS Gate Driver pull down resistance	$V_{SW}=0V$, $V_{DRVH}=0.2V$		0.3		Ω
R_{LS_DRV}	LS Gate Driver pull up resistance	$V_{IN}=12V$, $V_{DRVL}=5.8V$		0.9		Ω
	LS Gate Driver pull down resistance	$V_{IN}=12V$, $V_{DRVL}=0.2V$		0.3		Ω
T_{ONmin}	Recommend minimum turn-on time	High-side NMOS on			100	ns
T_{OFFmin}	Recommend Minimum Turn-off time	High-side NMOS off			100	ns
T_{PWMON}	PWM Dimming Minimum Turn-On time				100	ns
f_{SWmax}	PWM Dimming Maximum Duty Cycle				1	MHz
T_{SD}	Thermal Shutdown Temperature			170		$^{\circ}C$
T_{SDhys}	Thermal Shutdown hysteresis			30		$^{\circ}C$



Typical Performance Characteristics

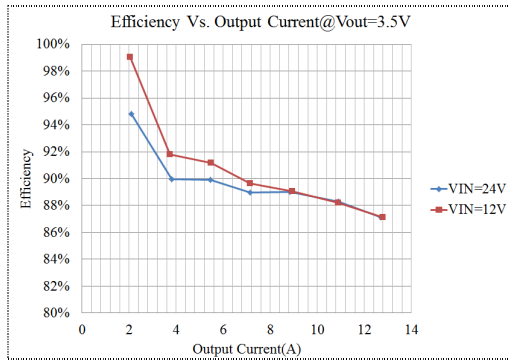

Fig 1 Efficiency

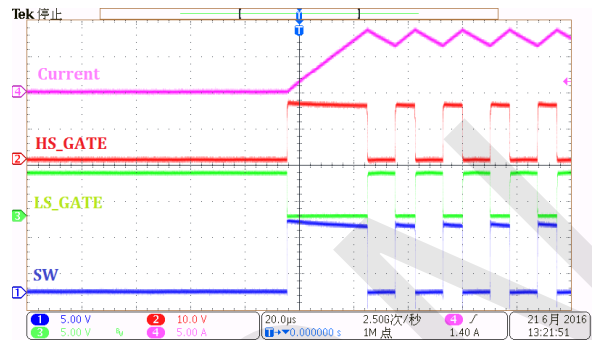

Fig 2 Start up Sequence

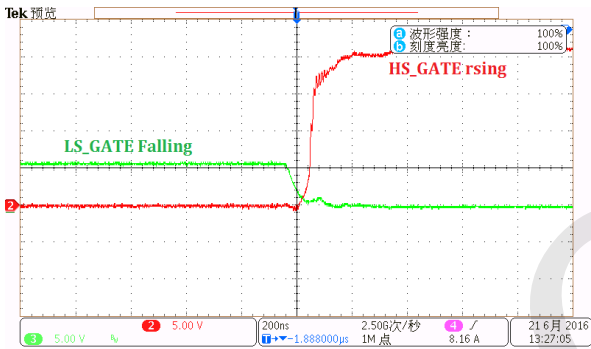

Fig 3 Dead time when SW toggle HIGH

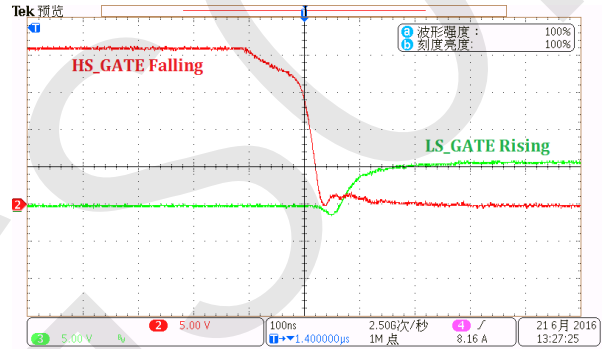

Fig 4 Dead time when SW toggle LOW

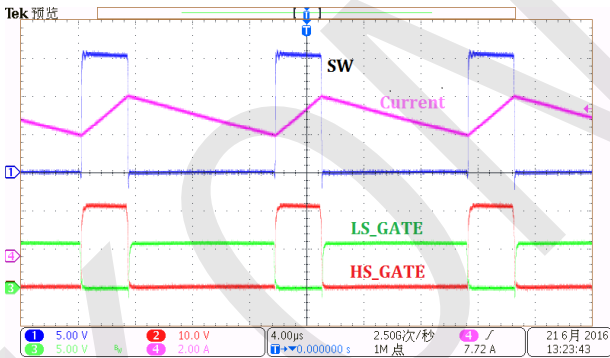
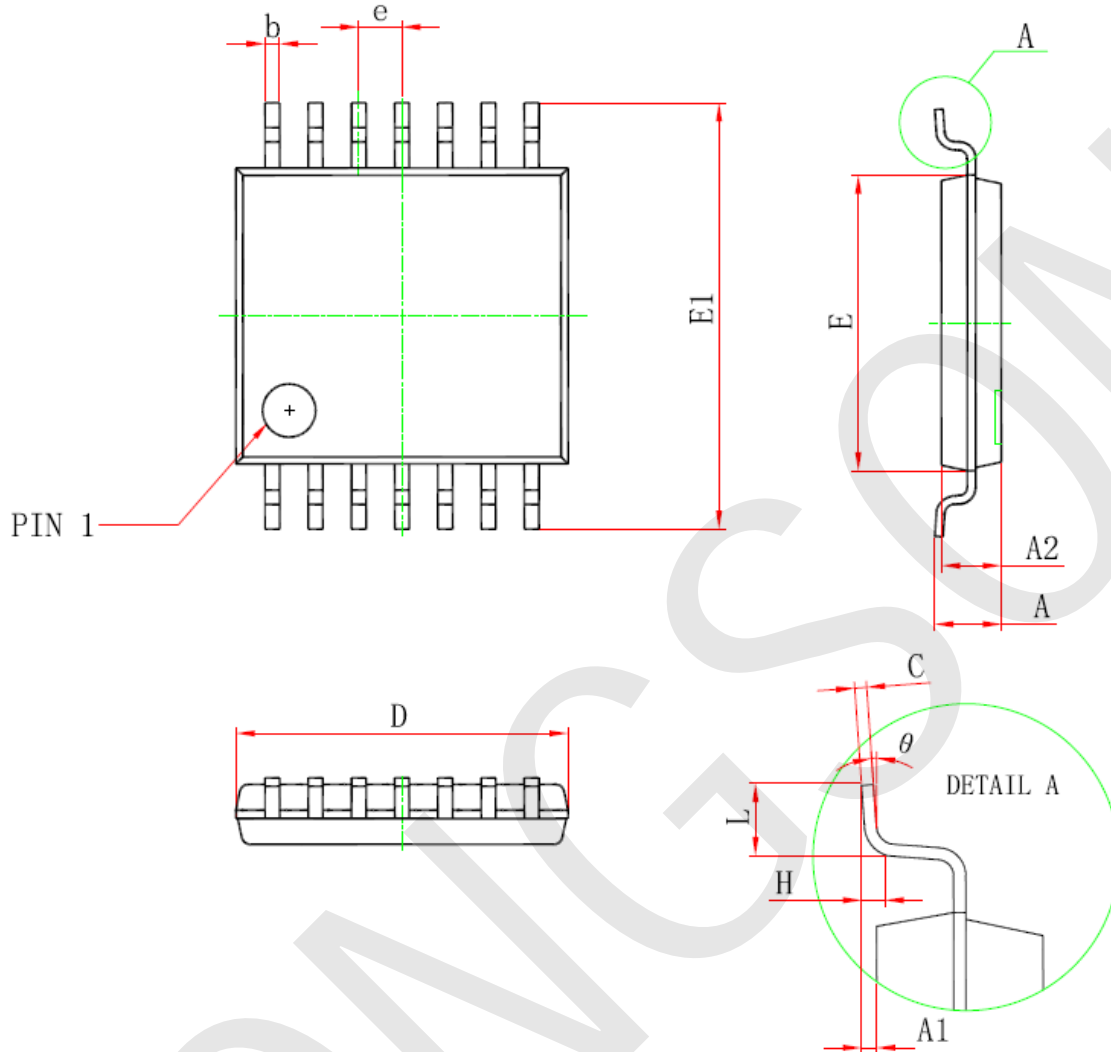

Fig 5 Normal Operation

Package Information (TSSOP-14)



Symbol	Dimensions In Millimeters		Dimensions In Inches	
	Min.	Max.	Min.	Max.
D	4.900	5.100	0.193	0.201
E	4.300	4.500	0.169	0.177
b	0.190	0.300	0.007	0.012
c	0.090	0.200	0.004	0.008
E1	6.250	6.550	0.246	0.258
A		1.200		0.047
A2	0.800	1.000	0.031	0.039
A1	0.050	0.150	0.002	0.006
e	0.65(BSC)		0.026(BSC)	
L	0.500	0.700	0.020	0.028
H	0.25(TYP)		0.01(TYP)	
θ	1°	7°	1°	7°