

60V/1.2A LED Driver with Internal Switch

General Description

The VAS1260 is a continuous mode inductive step-down converter, designed for driving single or multiple series connected LEDs efficiently from a voltage source higher than the LED voltage. The device operates from an input supply between 5V and 60V, and provides an externally adjustable output current of up to 1.2A. Depending upon supply voltage and external components, this can provide up to 30 watts of output power.

The VAS1260 includes the output switch and a high-side output current sensing circuit, which uses an external resistor to set the nominal average output current. Output current can be adjusted below the set value, by applying an external control signal to the 'ADJ' pin.

The device operates over the -40°C to $+85^{\circ}\text{C}$ temperature range and is available in SOT89-5 package.

Application

- Architectural, Industrial, Ambient and Car Lighting
- LED MR16, MR111
- PAR and other LED Bulbs

Typical Application Circuit

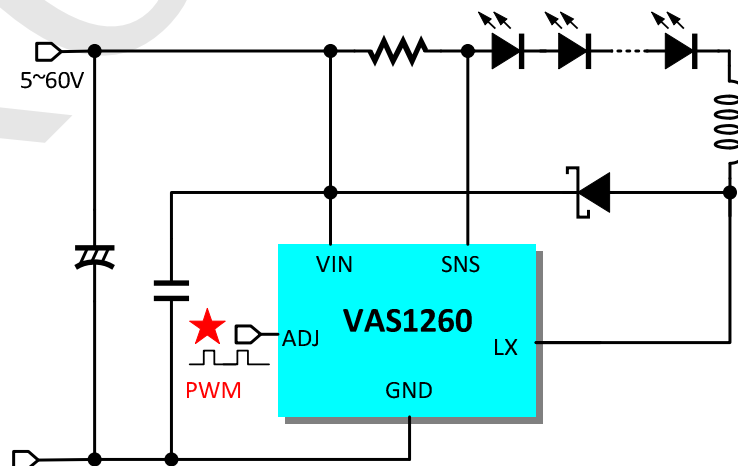

Features

- Simple low parts count
- Internal 60V NMOS switch
- 1.2A output current
- PWM dimming
- High efficiency (up to 95%)
- Wide input voltage range: 5V to 60V
- Over Temperature protection
- Up to 1MHz switching frequency
- Inherent open-circuit LED protection
- Typical 5% output current accuracy

Ordering Information

Order Number	Package Type	Temp. Range
VAS1260IB05E	SOT89-5	-40°C to 85°C

I: Industry, $-40\sim 85^{\circ}\text{C}$
05 : Pin Number

B: SOT
E: ROHS

Pin Configuration

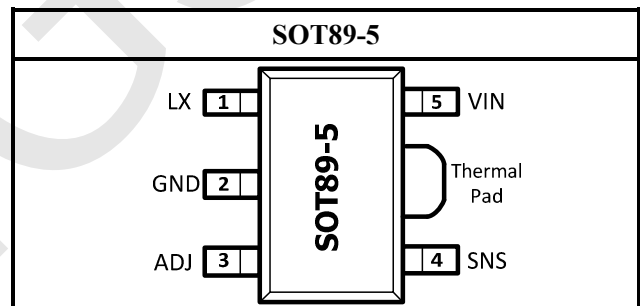

Block Diagram

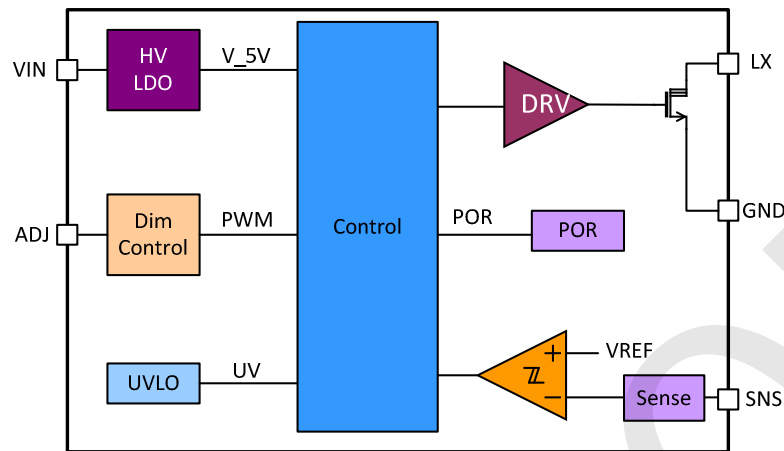

PIN Description

Name	PIN NO.	Description
LX	1	Drain of the internal NMOS
GND	2	Ground
ADJ	3	Multi-function On/Off and brightness control pin: <ul style="list-style-type: none"> • Drive to voltage below 0.5V to turn off output current and for over 30ms to shutdown the device • Leave floating for normal operation, output current $I_{OUTNOM}=0.1/R_{SNS}$ • Drive with a PWM signal to adjust output current
SNS	4	Current Sense Input
VIN	5	Positive Supply Voltage Input. Bypass with a 1 μ F or higher value capacitor to GND



Absolute Maximum Ratings^(Note1)

Parameters	Maximum Ratings
VIN, SNS, ADJ, LX to GND	-0.3V to 66V
VIN to SNS	-0.3V to +0.3V
Operating temperature range	-40°C to +85°C
Junction temperature	-40°C to +150°C
Storage temperature range	-65°C to +150°C
ESD human body model	2000V

Note 1: Absolute Maximum Ratings indicate limits beyond which damage to the device may occur. Operating Ratings indicate conditions for which the device is functional, but do not guarantee specific performance limits. Electrical Characteristics state DC and AC electrical specifications under particular test conditions which guarantee specific performance limits. This assumes that the device is within the Operating Ratings. Specifications are not guaranteed for parameters where no limit is given, however, the typical value is a good indication of device performance.

Electrical Characteristics

Typical case^(Note2): VCC=12V, T_A=25°C(unless otherwise specified)

Symbol	Parameter	Condition	spec			Unit
			Min.	Typ.	Max.	
VIN	Input voltage range		5		60	V
I _{CC}	Quiescent current	ADJ floating, all external devices open		350	600	μA
I _{SD}	Shutdown supply current	V _{ADJ} =0V		100	150	μA
UVLO	Under-voltage Lockout			3.5	3.7	V
UVLO-HYS	UVLO Hysteresis			0.2		V
SENSE COMPARATOR						
V _{SNS}	Mean current sense threshold voltage(defines LED current setting accuracy)	Measured on SNS pin with respect to VIN, ADJ pin floating	95	100	105	mV
V _{SNS_HYS}	Sense threshold hysteresis			±15%		
I _{SNS}	Current Sense Input Current	VIN-V _{SNS} =100mV		5		μA
T _{PD}	Internal comparator Propagation Delay			50		ns
DIMMING INPUT						
F _{PWM}	PWM dimming range		100		20,000	Hz
V _{IH}	PWM Dimming Input-Voltage-High				1.5	V
V _{IL}	PWM Dimming Input-Voltage-Low		0.5			V
T _{PWMOFF}	PWM Dimming Maximum Turn-Off time				15	ms
I _{LXmean}	Continuous LX switch current			1.2		A



R_{DSON}	LX switch 'on' resistance			0.3	0.5	Ω
$I_{\text{LX(leak)}}$	LX switch leakage current				1	μA
T_{ONmin}	Recommend maximum turn-on time			100		ns
T_{OFFmin}	Recommend minimum turn-off time			100		ns
F_{LXmax}	Recommend maximum operation frequency				1	MHz
THERMAL SHUTDOWN						
T_{SD}	Thermal shutdown temperature			170		$^{\circ}\text{C}$
T_{SDhys}	Thermal shutdown hysteresis			20		$^{\circ}\text{C}$

Note 2: Production testing of the device is performed at 25°C. Functional operation of the device and parameters specified over other temperature range, are guaranteed by design, characterization and process control.



Application Information

The VAS1260 is a step-down, constant-current, high-brightness LED(HBLED) driver. These devices operate from a 5V to 60V input voltage range and provide up to 1.2A continuous LX switch current. A high-side current-sense resistor sets the output current. ADJ allows for 100Hz~20KHz PWM signal dimming.

The high-side current-sense scheme and on-board current setting circuitry minimize the number of external components while delivering LED current with a $\pm 5\%$ accuracy, using a 1% sense resistor.

1. Under-Voltage Lockout (UVLO)

The VAS1260 include a 3.7V under-voltage lockout (UVLO) with 200mV hysteresis. When VIN falls below 3.5V, internal NMOS switches off and once VIN is 3.7V or higher, internal NMOS switches on.

2. ADJ Input

The VAS1260 allows PWM dimming.

When an external PWM signal is added at the ADJ input. A logic level below 0.5V at ADJ forces the internal NMOS off, turning off the LED current. To turn the LED current on, the logic level at ADJ must be at least 1.5V.

When ADJ is below 0.5V for over 30ms, the device will shut down and has less dissipation.

3. Over-Heating Issue

It is possible that the chip may be overheating caused by the unreasonable circuit design or operation, and the VAS1260 solve the issue by:

1) If the VAS1260 die temperature rises to 120°C (IC surface is about 90°C), LED current starts to decrease gradually.

2) If the temperature continues to increase to 170°C, VAS1260 enter thermal shutdown mode. When the temperature drops to 150°C, VAS1260 re-starts to work.

4. Selecting R_{SNS} to Set the LED Current

The VAS1260 feature a programmable LED current using a resistor connected between VIN and SNS. Use the following equation to calculate the sense resistor:

$$R_{SNS} = \frac{0.1}{I_{LED}}$$

The table below gives values of nominal average output current for several values of current setting resistors (R_{SNS}) in the typical application circuit shown on page 1.

R_{SNS} (Ω)	nominal average output current(mA)
0.5	200
0.3	333
0.1	1000

5. Current Regulator Operations

The VAS1260 regulate the LED output current using an input comparator with hysteresis (Show in the figure bellow).

As the current through the inductor ramps up and the voltage across the sense resistor reaches the



upper threshold, turning off the internal NMOS. The NMOS turns on again when the inductor current ramps down through the freewheeling diode until the voltage across the sense resistor equals the lower threshold. Use the following equation to determine the operating frequency:

$$F_{SW} = \frac{(V_{IN} - V_{OUT}) \times V_{OUT}}{V_{IN} \times \Delta I \times L}$$

Where ΔI is the coil peak-peak ripple

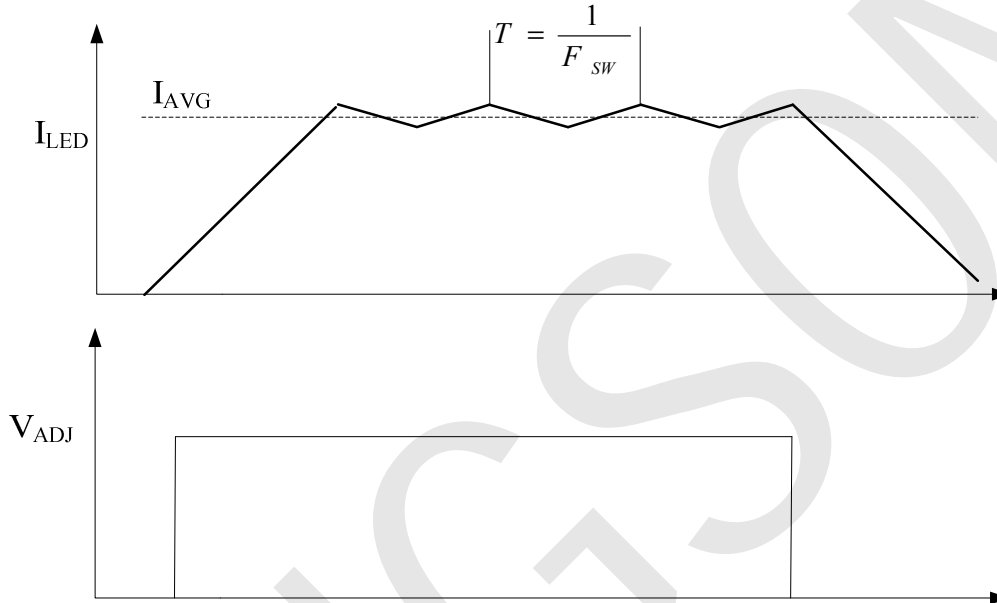

6. Inductor selection

Recommended inductor values for the VAS1260 are in the range 47 μ H to 470 μ H.

Higher values of inductance are recommended at higher supply voltages and low output current in order to minimize errors due to switching delays, which result in increased ripple and lower efficiency. Higher values of inductance also result in a smaller change in output current over the supply voltage range. The inductor should be mounted as close to the chip as possible with low resistance connections to the LX and V_{IN} pins.

The chosen coil should have a saturation current higher than the peak output current and a continuous current rating above the required mean output current. It is recommended to use inductor with saturation current larger than 500mA for 350mA output current.

The inductor value should be chosen to maintain operation duty cycle and switch 'on/off' times within the specified limits over the supply voltage and load current range. Following information can be used as a guide.

Internal NMOS Switch 'on' time:

$$T_{ON} = \frac{L \times \Delta I}{V_{IN} - V_{LED} - I_{AVG} (R_S + R_L + R_{DS(ON)})}$$

Note that : T_{ON}>100ns

Internal NMOS Switch 'off' time:



$$T_{OFF} = \frac{L \times \Delta I}{V_{LED} + V_D + I_{AVG} (R_S + R_L)}$$

Note that : $T_{OFF} > 100\text{ns}$

Where:

L is the coil inductor (H)

R_L is the resistance (Ω)

I_{AVG} is the required LED current (A)

ΔI is the coil peak-peak ripple current (A) (internally set to $0.2 \times I_{AVG}$)

V_{IN} is the supply voltage (V)

V_{LED} is the total LED forward voltage (V)

R_{DSON} is the switch resistor of NMOS (Ω)

V_D is the diode forward voltage at the required load current (V)

Example:

For $V_{IN}=12\text{V}$, $L=220\mu\text{H}$, $R_S=0.3\Omega$, $R_L=0.64\Omega$, $R_{DSON}=0.3\Omega$, $I_{AVG}=333\text{mA}$ and $V_D=0.36\text{V}$

$$T_{ON} = \frac{(220 \times 10^{-6} \times 0.067)}{(12 - 3.4 - 0.413)} = 1.8\mu\text{s}$$

$$T_{OFF} = \frac{(220 \times 10^{-6} \times 0.067)}{(3.4 + 0.36 + 0.313)} = 3.61\mu\text{s}$$

This gives an operating frequency of 184.8 kHz and a duty circle of 0.33.

7. LED Current Ripple

The LED current ripple is equal to the inductor current ripple. In cases when a lower LED current ripple is needed, a capacitor can be placed across the LED terminals.

8. Capacitor selection

A low ESR capacitor should be used for input decoupling, as the ESR of this capacitor appears in series with the supply source impedance and lowers overall efficiency. This capacitor has to supply the relatively high peak current to the coil and smooth the current ripple on the supply.

If the source is DC supply, the capacitor is decided by the ripple of the source, the value is given by:

$$C_{\min} = \frac{I_{OUT} \times T_{ON}}{\Delta U_{\max}}$$

I_{OUT} is the value of output current, ΔU_{\max} is the ripple of power supply. T_{ON} is the 'ON' time of internal NMOS. The value is normally 2 times of the minimum value. Recommend a 100 μF capacitor or larger.

9. Schottky Diode Selection

The Schottky diode breakdown voltage should high enough to withstand the maximum operating voltage and its forward current rating must be higher than the maximum LED current.

10. PCB Layout

Careful PCB layout is critical to achieve low switching losses and stable operation. Use a multilayer board whenever possible for better noise immunity. Minimize ground noise by connecting high-current ground returns, the input bypass-capacitor ground lead, and the output-filter ground lead

to a single point (star ground configuration). In normal operation, there are two power loops. One is formed when the internal NMOS is on and the high current flows through VIN— R_{SNS} —LEDs—Inductor—LX—GND. The other loop is formed when the internal NMOS is off when the high current circulates through R_{SNS} —LEDs—Inductor—Schottky diode. To minimize noise interaction, each loop area should be as small as possible.

Place R_{SNS} as close as possible to the input filter and VIN. For better noise immunity, a Kelvin connection is strongly recommended between SNS and R_{SNS} .



Package Information (SOT89-5)

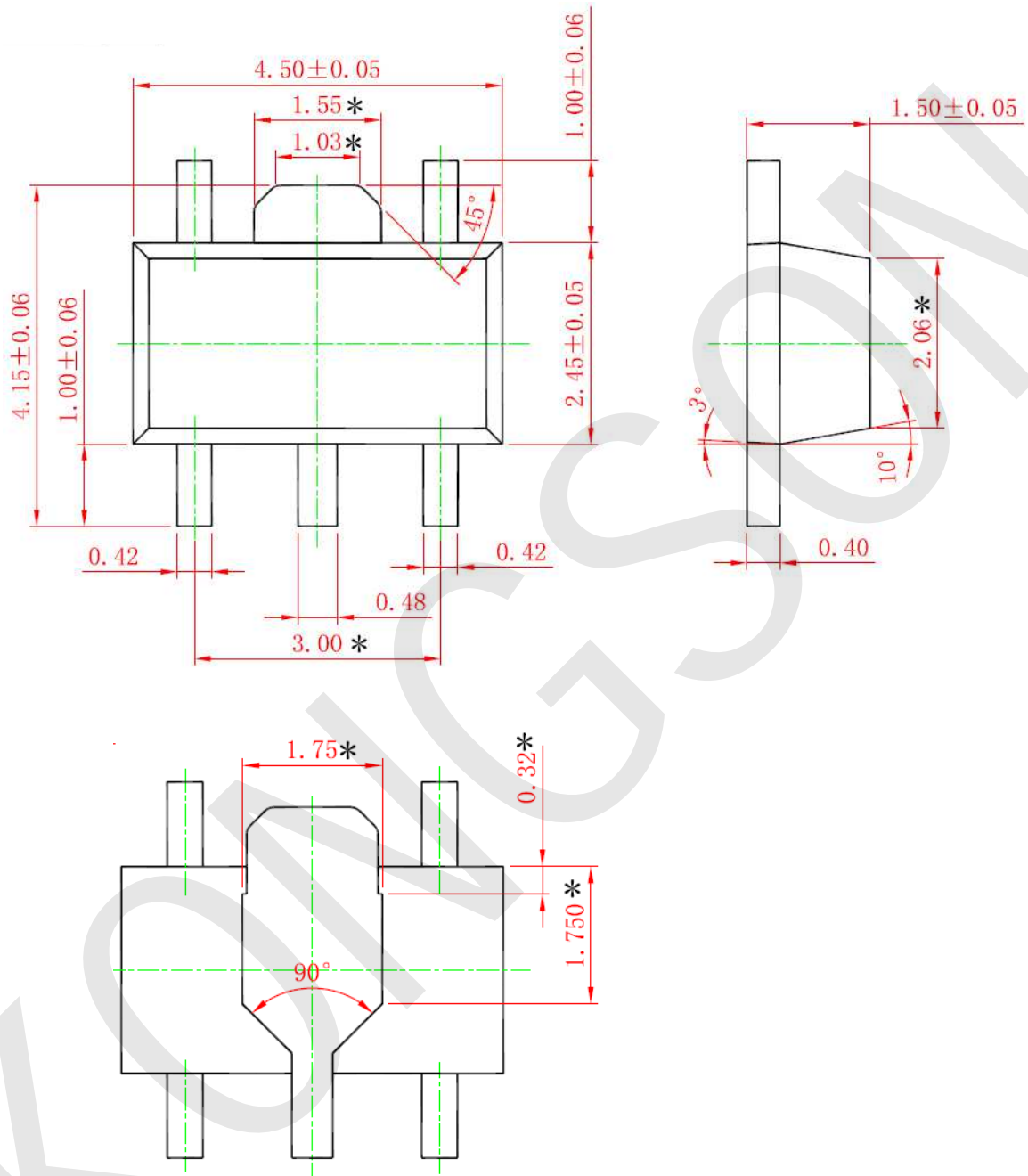

Classification Reflow Profiles

Profile Feature	Pb-Free Assembly
Preheat & Soak Temperature min (T _{smin})	150°C
Temperature max(T _{smax})	200°C
Time (T _{smin} to T _{smax}) (t _s)	60 -120 seconds
Average ramp-up rate (T _{smax} to T _p)	3°C/second max.
Liquidous temperature (T _L)	217 °C
Time at liquidous (t _L)	60 -150 seconds
Peak package body temperature (T _p)*	Max 260°C
Time (t _p)* * within 5°C of the specified classification temperature (T _c)	Max 30 seconds
Average ramp-down rate (T _p to T _{smax})	6°C/second max.
Time 25 °C to peak temperature	8 minutes max

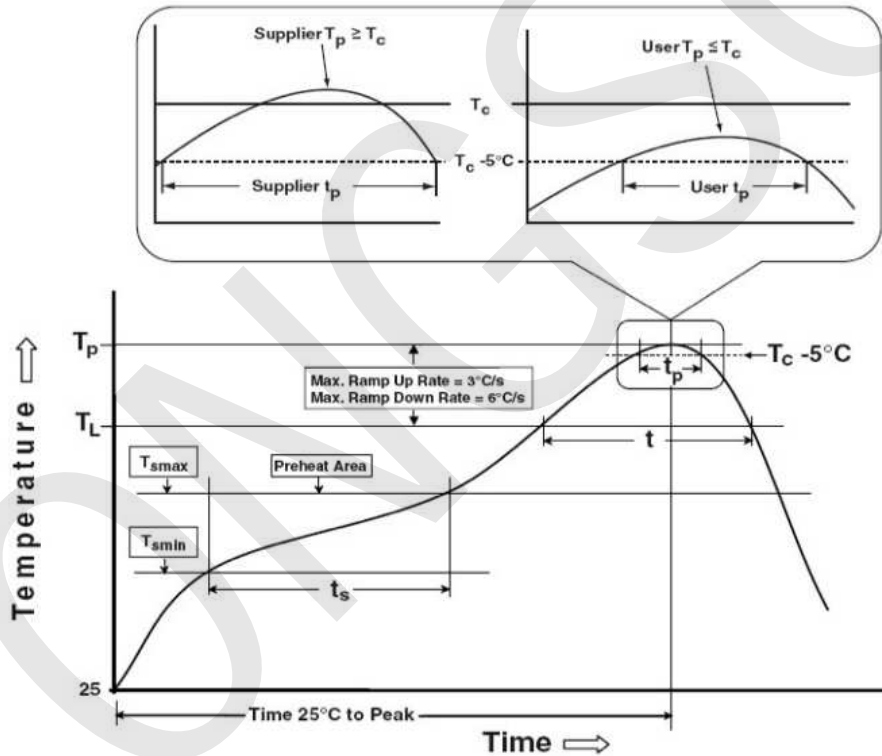

Classification Profile

! CAUTION

Storage Conditions

- 1) This product should be used within 12 months after delivered. Store in manufacturer's package keeping the seal of aluminum coated baggage or tightly re-closed box with the following conditions. [Temperature: 8°C...30°C, Humidity: 30%...70%R.H.]
- 2) Keep the seal of aluminum coated baggage immediately before usage.
- 3) After breaking the seal of aluminum coated baggage, this product should be used within 1 week on the following conditions. [Temperature: ≤30°C, Humidity: ≤60%R.H.]