
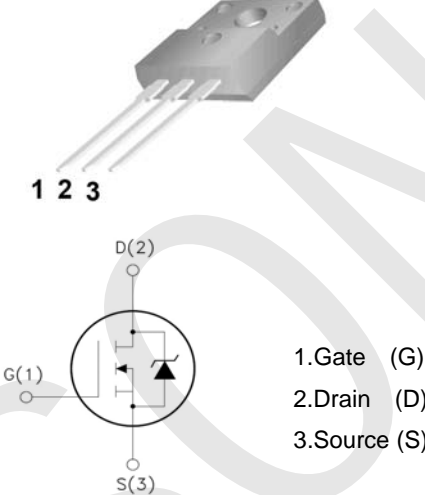


### SM5N60C

**Features:**

- Low Intrinsic Capacitances.
- Excellent Switching Characteristics.
- Extended Safe Operating Area.
- Unrivalled Gate Charge : $Q_g=16nC$  (Typ.).
- $BVDSS=600V, I_D=5A$
- $R_{DS(on)} : 2.2\Omega$  (Max) @ $V_G=10V$
- 100% Avalanche Tested

TO-220F

1.Gate (G)  
2.Drain (D)  
3.Source (S)

### Absolute Maximum Ratings ( $T_a=25^\circ C$ unless otherwise noted)

Symbol	Parameter	Value	Unit
$V_{DSS}$	Drain-Source Voltage	600	V
$I_D$	Drain Current	$T_j=25^\circ C$	5
		$T_j=100^\circ C$	3.15
$V_{GS(TH)}$	Gate Threshold Voltage	$\pm 30$	V
$E_{AS}$	Single Pulse Avalanche Energy (note1)	300	mJ
$I_{AR}$	Avalanche Current (note2)	5	A
$P_D$	Power Dissipation ( $T_j=25^\circ C$ )	50	W
$T_j$	Junction Temperature(Max)	150	$^\circ C$
$T_{stg}$	Storage Temperature	-55~+150	$^\circ C$
TL	Maximum lead temperature for soldering purpose, 1/8" from case for 5 seconds	300	$^\circ C$

### Thermal Characteristics

Symbol	Parameter	Typ.	Max.	Unit
$R_{\theta JC}$	Thermal Resistance, Junction to Case	-	1.04	$^\circ C/W$
$R_{\theta JA}$	Thermal Resistance, Junction to Ambient	-	62.5	$^\circ C/W$

### Electrical Characteristics (Ta=25°C unless otherwise noted)

Symbol	Parameter	Test Condition	Min.	Typ.	Max.	Unit
<b>Off Characteristics</b>						
BV <sub>DSS</sub>	Drain-Source Breakdown Voltage	I <sub>D</sub> =250μA, V <sub>GS</sub> =0	600	-	-	V
ΔBV <sub>DSS</sub> /ΔT <sub>J</sub>	Breakdown Voltage Temperature Coefficient	I <sub>D</sub> =250μA, Reference to 25°C	-	0.6	-	V/°C
I <sub>DSS</sub>	Zero Gate Voltage Drain Current	V <sub>DS</sub> =600V, V <sub>GS</sub> =0V	-	-	10	μA
		V <sub>DS</sub> =480V, T <sub>J</sub> =125°C	-	-	100	
I <sub>GSSF</sub>	Gate-body leakage Current, Forward	V <sub>GS</sub> =+30V, V <sub>DS</sub> =0V	-	-	100	nA
I <sub>GSSR</sub>	Gate-body leakage Current, Reverse	V <sub>GS</sub> =-30V, V <sub>DS</sub> =0V	-	-	-100	
<b>On Characteristics</b>						
V <sub>GS(TH)</sub>	Date Threshold Voltage	I <sub>D</sub> =250μA, V <sub>DS</sub> =V <sub>GS</sub>	2	-	4	V
R <sub>DS(ON)</sub>	Static Drain-Source On-Resistance	I <sub>D</sub> =2A, V <sub>GS</sub> =10V	-	-	2.2	Ω
<b>Dynamic Characteristics</b>						
C <sub>iss</sub>	Input Capacitance	V <sub>DS</sub> =25V, V <sub>GS</sub> =0, f=1.0MHz	-	560	730	pF
C <sub>oss</sub>	Output Capacitance		-	80	100	
C <sub>rss</sub>	Reverse Transfer Capacitance		-	9	12	
<b>Switching Characteristics</b>						
T <sub>d(on)</sub>	Turn-On Delay Time	V <sub>DD</sub> =300V, I <sub>D</sub> =5A R <sub>G</sub> =25Ω (Note 3,4)	-	13	35	ns
T <sub>r</sub>	Turn-On Rise Time		-	45	100	
T <sub>d(off)</sub>	Turn-Off Delay Time		-	35	80	
T <sub>f</sub>	Turn-Off Rise Time		-	40	90	
Q <sub>g</sub>	Total Gate Charge	V <sub>DS</sub> =480V, V <sub>GS</sub> =10V, I <sub>D</sub> =5A (Note 3,4)	-	16	20	nC
Q <sub>gs</sub>	Gate-Source Charge		-	3.5	-	
Q <sub>gd</sub>	Gate-Drain Charge		-	7.8	-	
<b>Drain-Source Diode Characteristics and Maximum Ratings</b>						
I <sub>S</sub>	Max. Diode Forward Current	-	-	-	5	A
I <sub>SM</sub>	Max. Pulsed Forward Current	-	-	-	20	
V <sub>SD</sub>	Diode Forward Voltage	I <sub>D</sub> =5A	-	-	1.5	V
T <sub>rr</sub>	Reverse Recovery Time	I <sub>S</sub> =5A, V <sub>GS</sub> =0V diF/dt=100A/μs	-	270	-	nS
Q <sub>rr</sub>	Reverse Recovery Charge	(Note3)	-	1.9	-	μC

- Notes : 1, L=24mH, I<sub>AS</sub>=5A, V<sub>DD</sub>=50V, R<sub>G</sub>=25Ω, Starting T<sub>J</sub>=25°C  
 2, Repetitive Rating : Pulse width limited by maximum junction temperature  
 3, Pulse Test : Pulse Width ≤ 300μs, Duty Cycle ≤ 2%  
 4, Essentially Independent of Operating Temperature

### Typical Characteristics

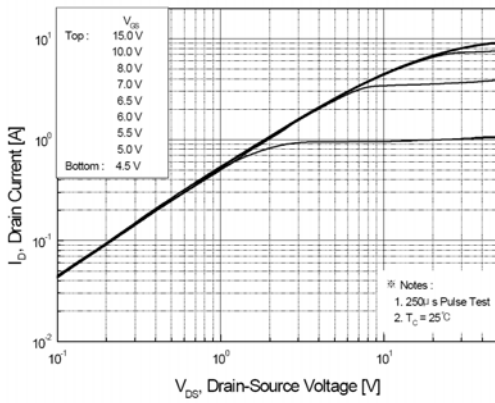


Figure 1. On-Region Characteristics

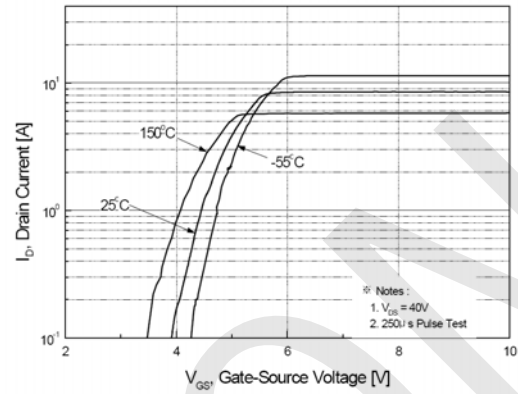


Figure 2. Transfer Characteristics

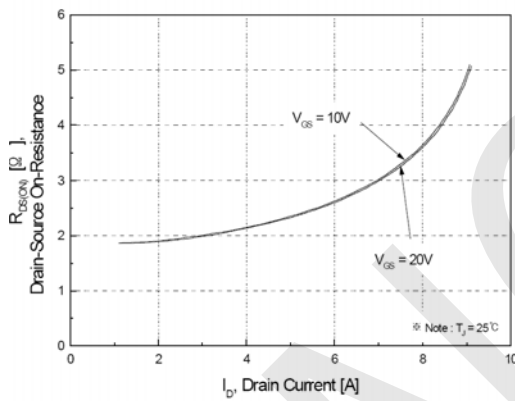


Figure 3. On-Resistance Variation vs Drain Current and Gate Voltage

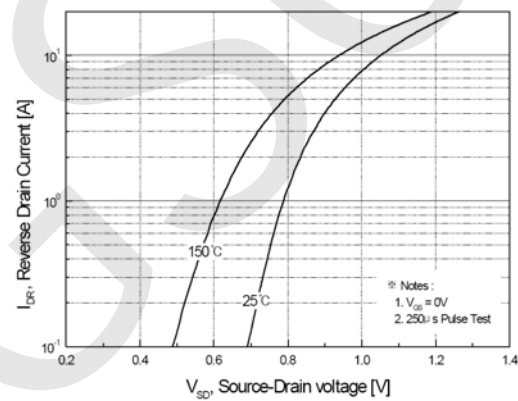


Figure 4. Body Diode Forward Voltage Variation with Source Current and Temperature

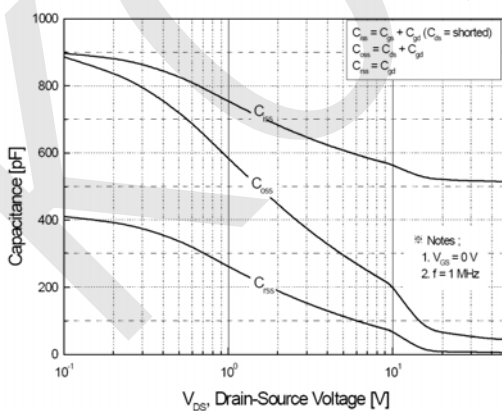


Figure 5. Capacitance Characteristics

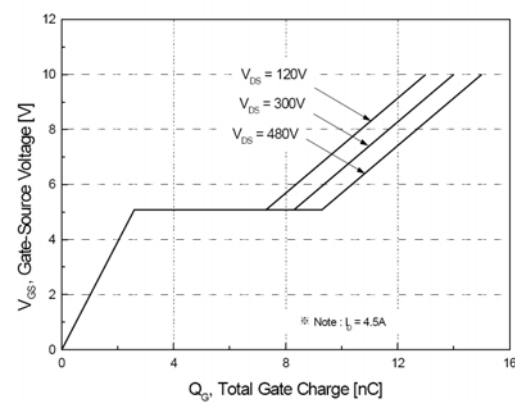
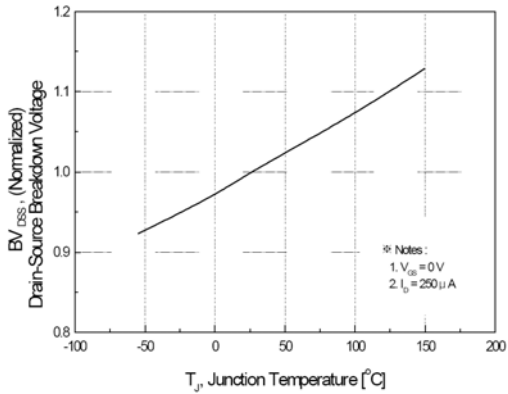
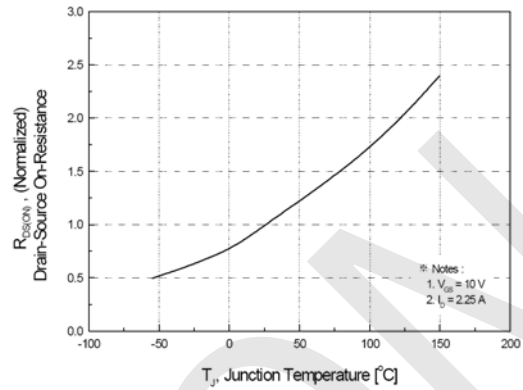


Figure 6. Gate Charge Characteristics

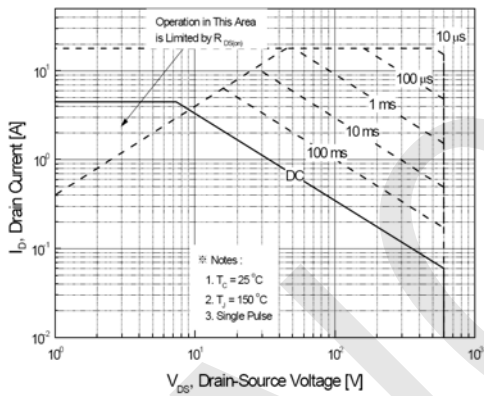
### Typical Characteristics (Continued)



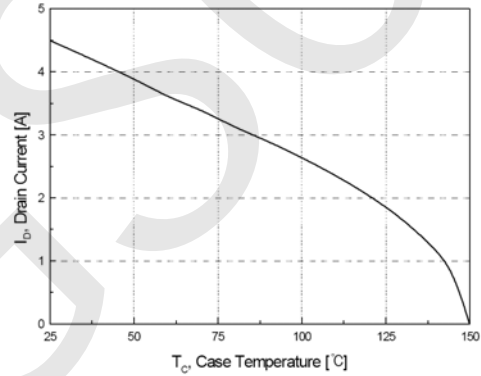
**Figure 7. Breakdown Voltage Variation vs Temperature**



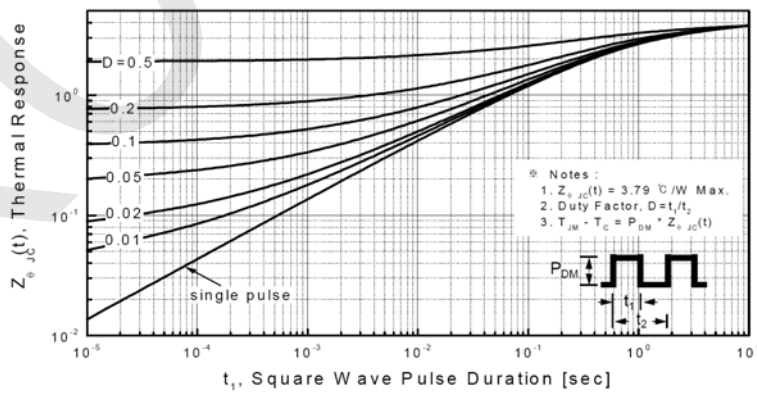
**Figure 8. On-Resistance Variation vs Temperature**



**Figure 9. Maximum Safe Operating Area for WGF5N60**

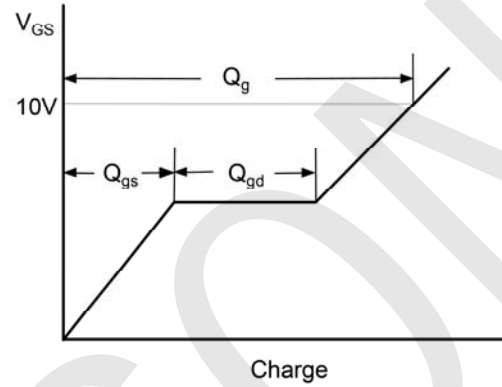
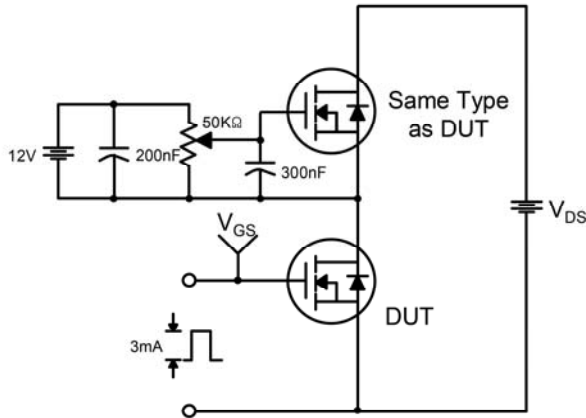


**Figure 10. Maximum Drain Current vs Case Temperature**

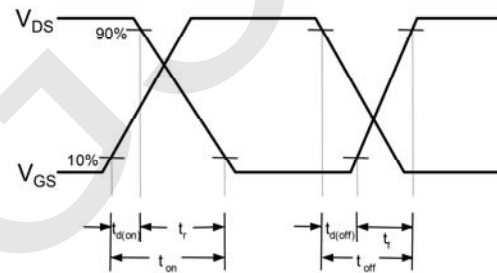
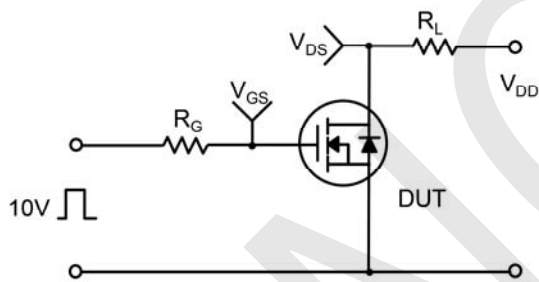


**Figure 11. Transient Thermal Response Curve for WGF5N60**

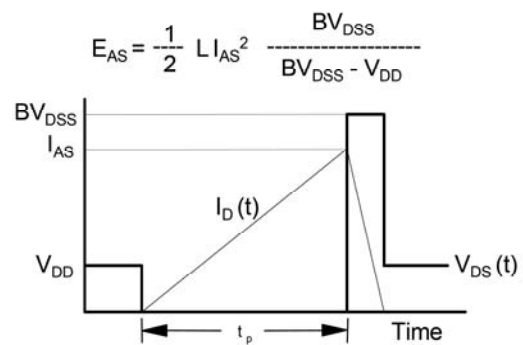
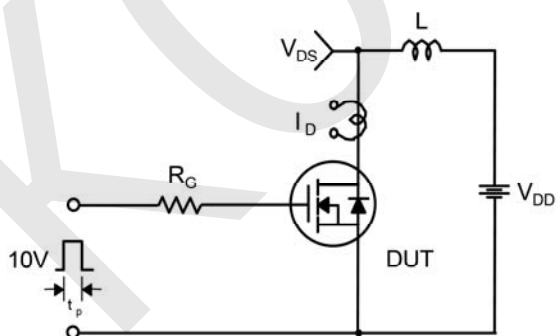
### Gate Charge Test Circuit & Waveform



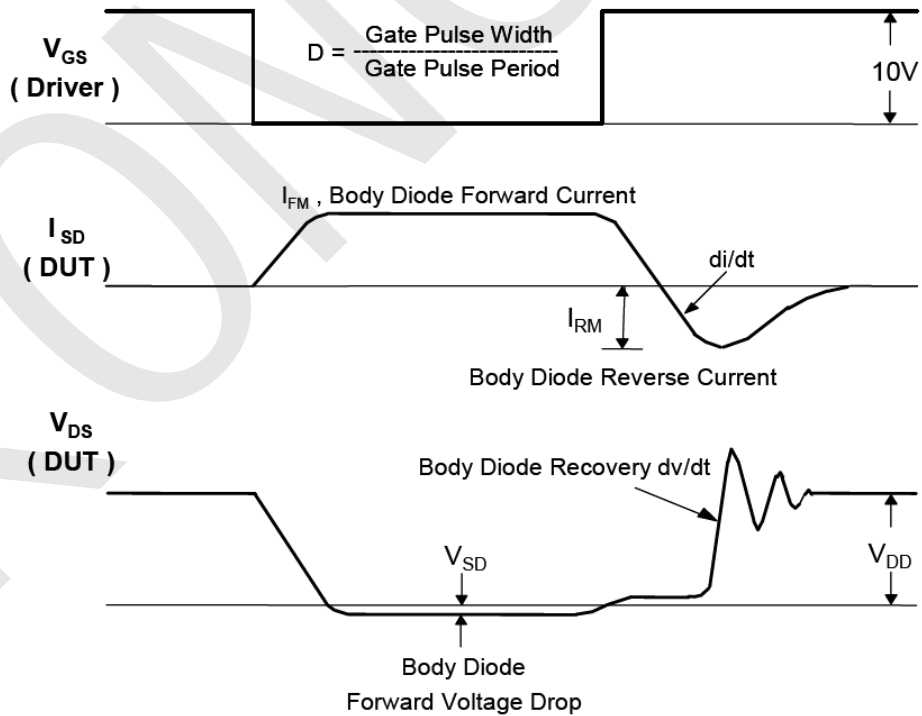
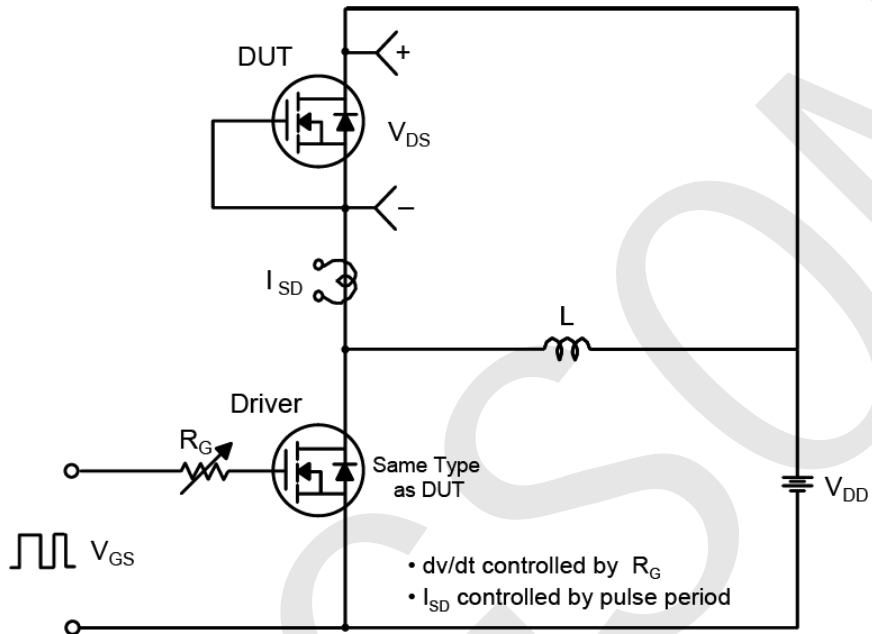
### Resistive Switching Test Circuit & Waveforms



### Unclamped Inductive Switching Test Circuit & Waveforms



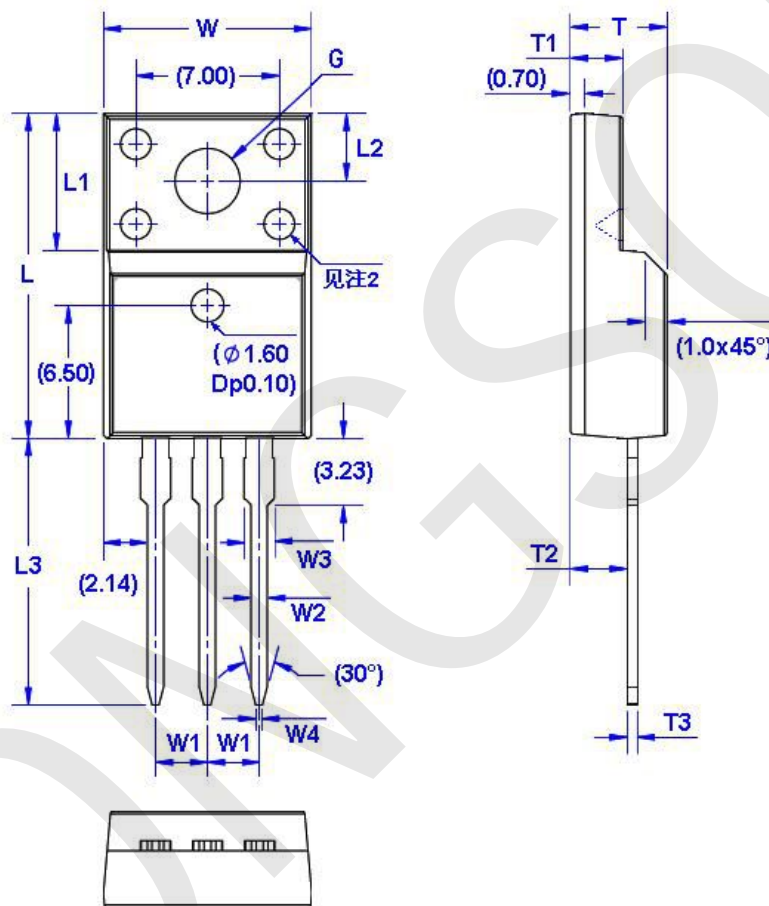
### Peak Diode Recovery dv/dt Test Circuit & Waveform



### Package Dimension

### TO-220F

Unit: mm



Symbol	Size		Symbol	Size		Symbol	Size		Symbol	Size	
	Min	Max		Min	Max		Min	Max		Min	Max
W	9.96	10.36	W4	0.25	0.45	L3	12.78	13.18	T3	0.45	0.60
W1	2.54 (TYP)		L	15.67	16.07	T	4.50	4.90	G( $\Phi$ )	3.08	3.28
W2	0.70	0.90	L1	6.48	6.88	T1	2.34	2.74			
W3	1.24	1.47	L2	3.20	3.40	T2	2.56	2.96			