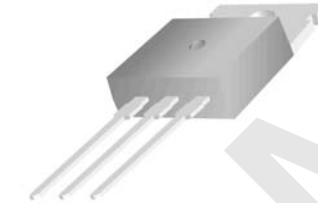
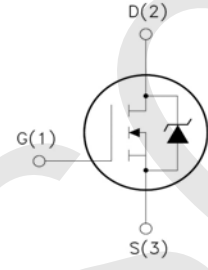

### SM13N50S

**Features:**

- Low Intrinsic Capacitances
- Excellent Switching Characteristics
- Extended Safe Operating Area
- Unrivalled Gate Charge :Qg= 42nC (Typ.)
- BVDSS=500V, ID=13A
- R<sub>DS(on)</sub> :0.52 Ω (Max) @VG=10V
- 100% Avalanche Tested

TO-220

1.Gate (G)  
2.Drain (D)  
3.Source (S)

### Absolute Maximum Ratings (Ta=25°C unless otherwise noted)

Symbol	Parameter	Value	Unit
V <sub>DSS</sub>	Drain-Source Voltage	500	V
I <sub>D</sub>	Drain Current	T <sub>j</sub> =25°C	13
		T <sub>j</sub> =100°C	7.9
V <sub>GS(TH)</sub>	Gate Threshold Voltage	±30	V
E <sub>AS</sub>	Single Pulse Avalanche Energy (note1)	651	mJ
I <sub>AR</sub>	Avalanche Current (note2)	13	A
P <sub>D</sub>	Power Dissipation (T <sub>j</sub> =25°C)	132	W
T <sub>j</sub>	Junction Temperature(Max)	150	°C
T <sub>stg</sub>	Storage Temperature	-55~+150	°C
TL	Maximum lead temperature for soldering purpose, 1/8" from case for 5 seconds	300	°C

### Thermal Characteristics

Symbol	Parameter	Typ.	Max.	Unit
R <sub>θJC</sub>	Thermal Resistance, Junction to Case	-	0.94	°C/W
R <sub>θJA</sub>	Thermal Resistance, Junction to Ambient	-	62.5	°C/W

**Electrical Characteristics** (Ta=25°C unless otherwise noted)

Symbol	Parameter	Test Condition	Min.	Typ.	Max.	Unit
<b>Off Characteristics</b>						
BV <sub>DSS</sub>	Drain-Source Breakdown Voltage	I <sub>D</sub> =250μA, V <sub>GS</sub> =0	500	-	-	V
ΔBV <sub>DSS</sub> /ΔT <sub>J</sub>	Breakdown Voltage Temperature Coefficient	I <sub>D</sub> =250μA, Reference to 25°C	-	0.48	-	V/°C
I <sub>DSS</sub>	Zero Gate Voltage Drain Current	V <sub>DS</sub> =500V, V <sub>GS</sub> =0V	-	-	1	μA
		V <sub>DS</sub> =400V, T <sub>J</sub> =125°C			100	
I <sub>GSSF</sub>	Gate-body leakage Current, Forward	V <sub>GS</sub> =+30V, V <sub>DS</sub> =0V	-	-	100	nA
I <sub>GSSR</sub>	Gate-body leakage Current, Reverse	V <sub>GS</sub> =-30V, V <sub>DS</sub> =0V	-	-	-100	
<b>On Characteristics</b>						
V <sub>GS(TH)</sub>	Date Threshold Voltage	I <sub>D</sub> =250μA, V <sub>DS</sub> =V <sub>GS</sub>	2	-	4	V
R <sub>DS(ON)</sub>	Static Drain-Source On-Resistance	I <sub>D</sub> =6.5A, V <sub>GS</sub> =10V	-	0.42	0.52	Ω
<b>Dynamic Characteristics</b>						
C <sub>iss</sub>	Input Capacitance	V <sub>DS</sub> =25V, V <sub>GS</sub> =0, f=1.0MHz	-	1788	-	pF
C <sub>oss</sub>	Output Capacitance		-	184	-	
C <sub>rss</sub>	Reverse Transfer Capacitance		-	30	-	
<b>Switching Characteristics</b>						
T <sub>d(on)</sub>	Turn-On Delay Time	V <sub>DD</sub> =250V, I <sub>D</sub> =13A R <sub>G</sub> =25Ω (Note 3,4)	-	4.6	-	nS
T <sub>r</sub>	Turn-On Rise Time		-	10.4	-	
T <sub>d(off)</sub>	Turn-Off Delay Time		-	40.6	-	
T <sub>f</sub>	Turn-Off Rise Time		-	10.2	-	
Q <sub>g</sub>	Total Gate Charge	V <sub>DS</sub> =400V, V <sub>GS</sub> =10V, I <sub>D</sub> =13A (Note 3,4)	-	42	-	nC
Q <sub>gs</sub>	Gate-Source Charge		-	7	-	
Q <sub>gd</sub>	Gate-Drain Charge		-	15	-	
<b>Drain-Source Diode Characteristics and Maximum Ratings</b>						
I <sub>S</sub>	Max. Diode Forward Current	-	-	-	13	A
I <sub>SM</sub>	Max. Pulsed Forward Current	-	-	-	52	
V <sub>SD</sub>	Diode Forward Voltage	I <sub>D</sub> =13A	-	-	1.4	V
T <sub>rr</sub>	Reverse Recovery Time	I <sub>S</sub> =13A, V <sub>GS</sub> =0V diF/dt=100A/μs	-	309	-	nS
Q <sub>rr</sub>	Reverse Recovery Charge	(Note3)	-	2.7	-	μC

Notes : 1, L=17.1mH, I<sub>AS</sub>=13A, V<sub>DD</sub>=50V, R<sub>G</sub>=25Ω, Starting T<sub>J</sub>=25°C

2, Repetitive Rating : Pulse width limited by maximum junction temperature

3, Pulse Test : Pulse Width ≤ 300μs, Duty Cycle ≤ 2%

4, Essentially Independent of Operating Temperature

### Typical Characteristics

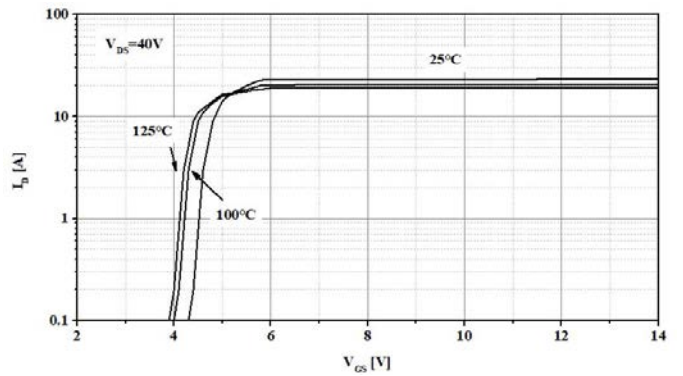
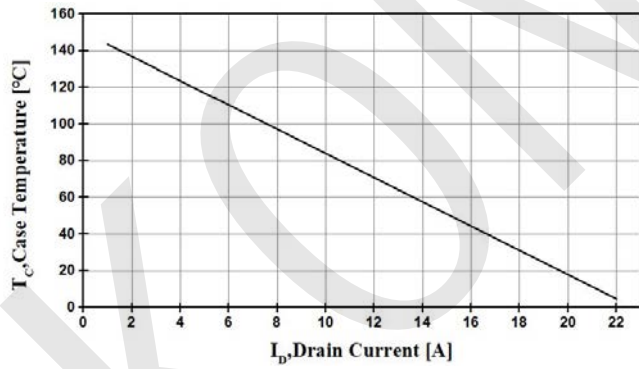
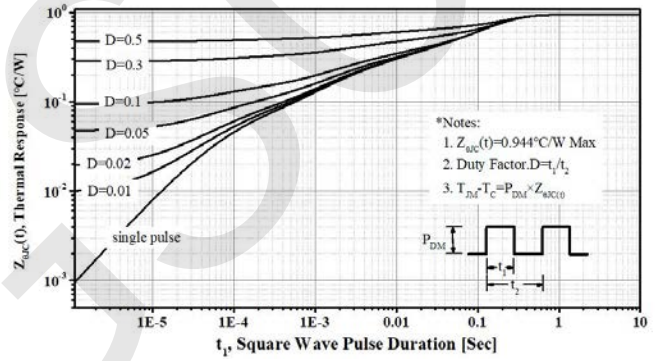
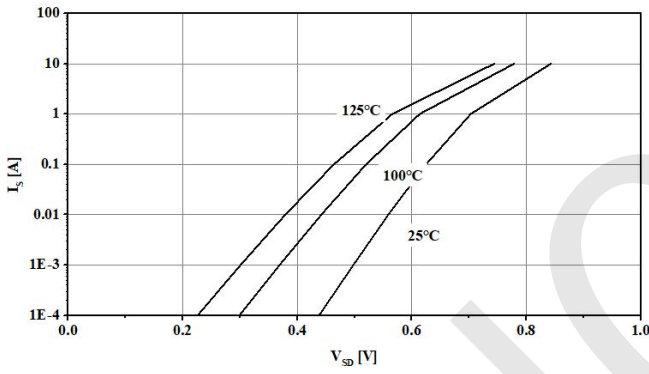
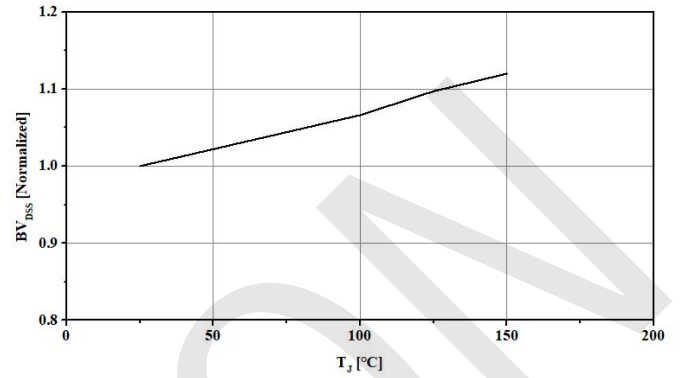
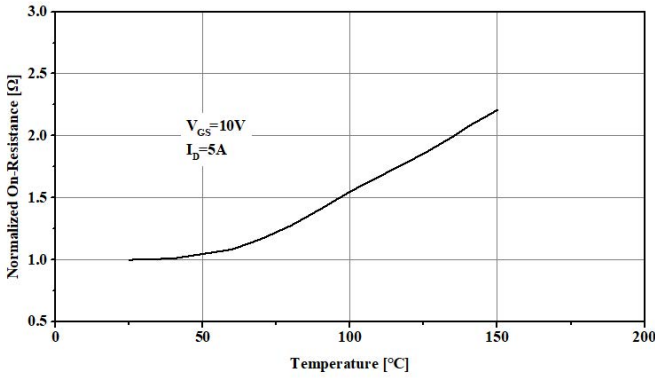

#### Typical Characteristics (Continued)

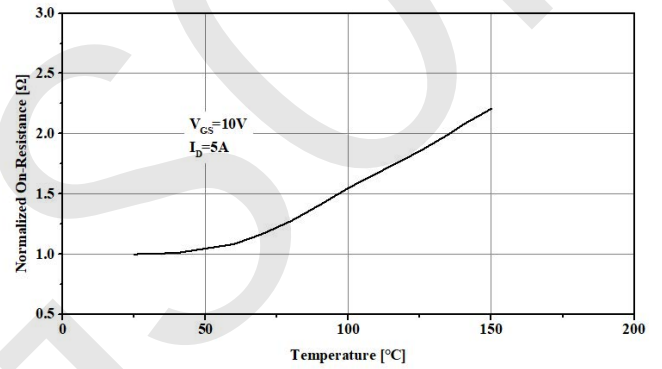
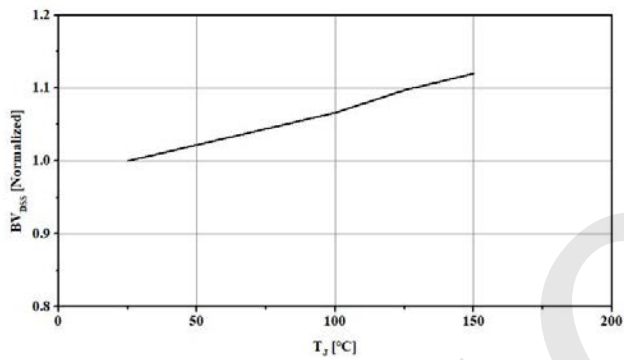
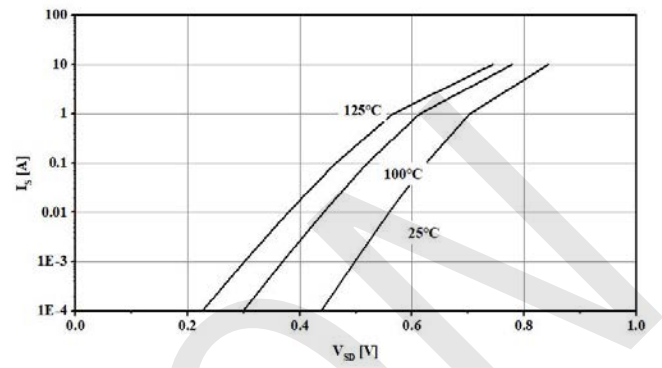
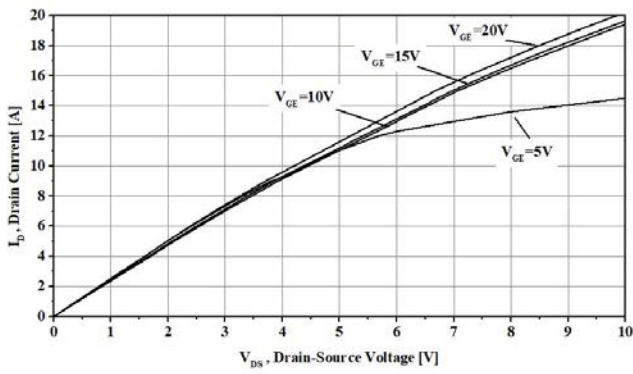

#### Gate Charge Test Circuit & Waveform

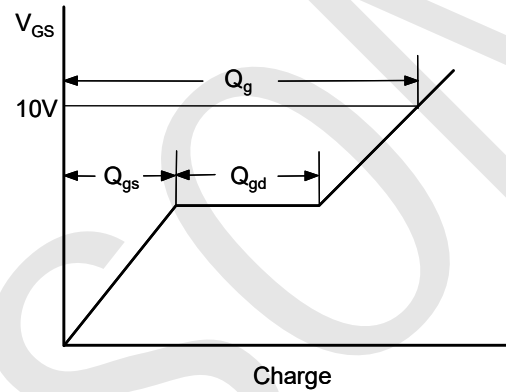
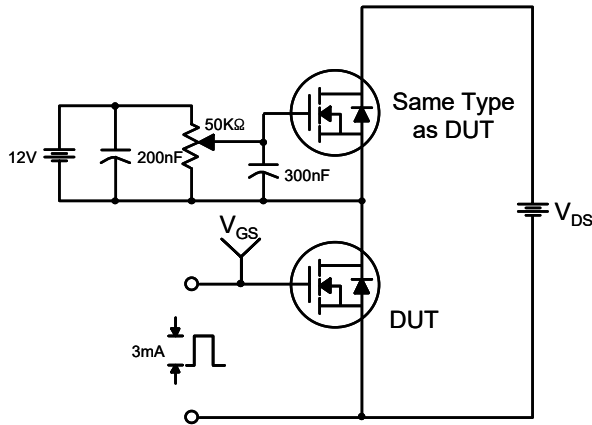

#### Resistive Switching Test Circuit & Waveforms

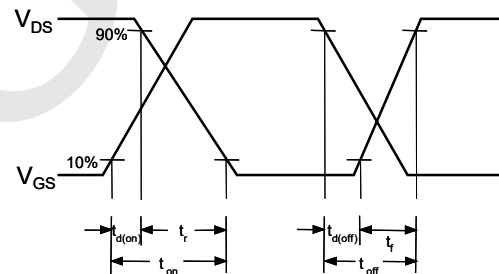
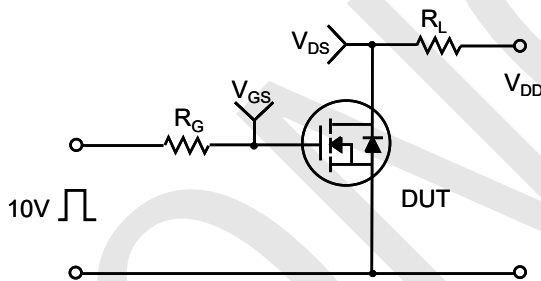

#### Unclamped Inductive Switching Test Circuit & Waveforms

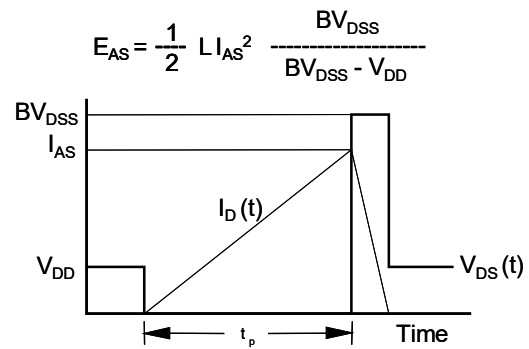
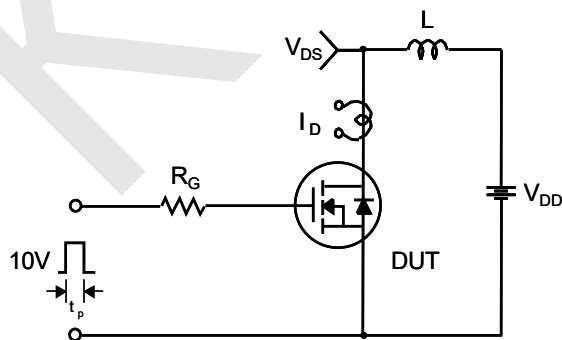

### Peak Diode Recovery dv/dt Test Circuit & Waveforms

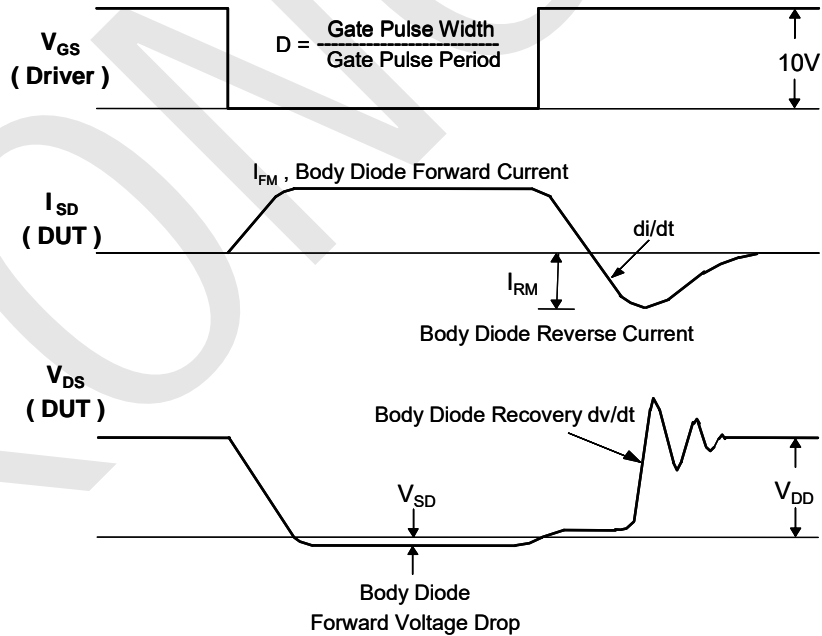
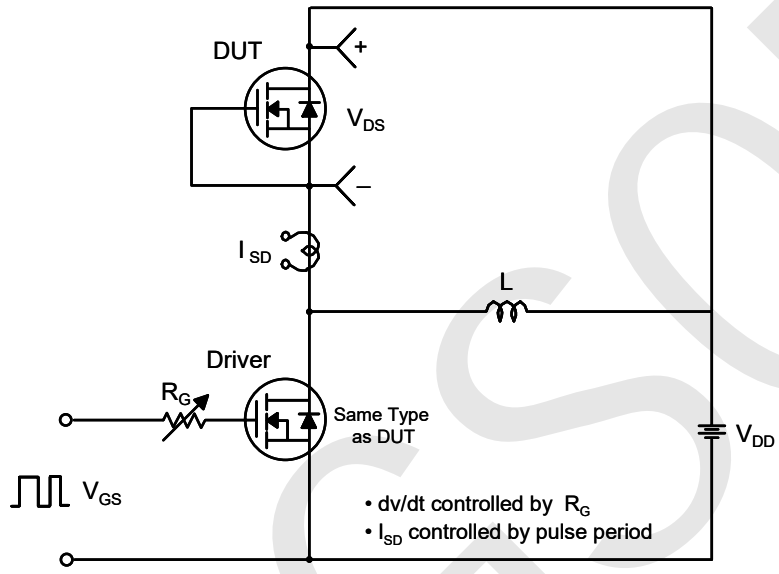

### Package Dimension

### TO-220

Unit:mm

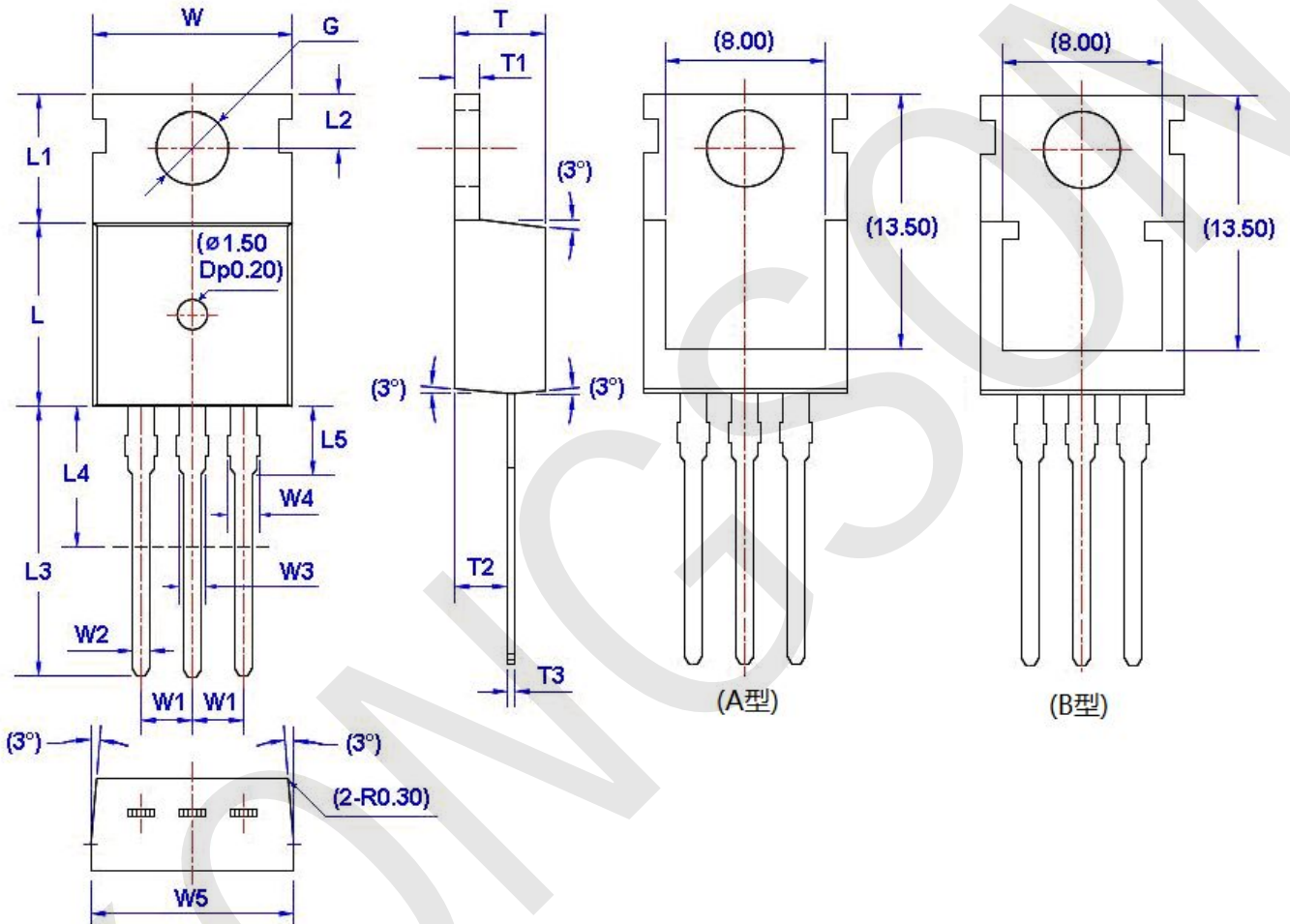

Symbol	Size		Symbol	Size		Symbol	Size		Symbol	Size	
	Min	Max		Min	Max		Min	Max		Min	Max
W	9.66	10.28	W5	9.80	10.20	L4**	6.20	6.60	T3	0.45	0.60
W1	2.54 (TYP)		L	9.00	9.40	L5	2.79	3.30	G( $\Phi$ )	3.50	3.70
W2	0.70	0.95	L1	6.40	6.80	T	4.30	4.70			
W3	1.17	1.37	L2	2.70	2.90	T1	1.15	1.40			
W4*	1.32	1.72	L3	12.70	14.27	T2	2.20	2.60			