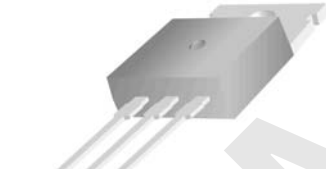
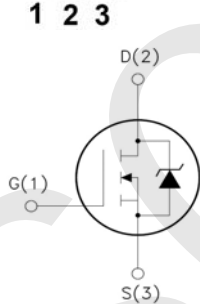

SM840S

Features

- Low Intrinsic Capacitances
- Excellent Switching Characteristics
- Extended Safe Operating Area
- Unrivalled Gate Charge : 28 nC (Typ.)
- BVDSS=500V, ID=9A
- Lower $R_{DS(on)}$: 0.75 Ω (Max) @VG=10V
- 100% Avalanche Tested

TO-220

1.Gate (G)
2.Drain (D)
3.Source (S)

Absolute Maximum Ratings (Ta=25°C unless otherwise noted)

Symbol	Parameter	Value	Unit
V_{DSS}	Drain-Source Voltage	500	V
I_D	Drain Current	$T_j=25^\circ\text{C}$	9.0
		$T_j=100^\circ\text{C}$	5.7
$V_{GS(TH)}$	Gate Threshold Voltage	± 30	V
E_{AS}	Single Pulse Avalanche Energy (note1)	360	mJ
I_{AR}	Avalanche Current (note2)	9.0	A
P_D	Power Dissipation ($T_j=25^\circ\text{C}$)	140	W
T_j	Junction Temperature(Max)	150	$^\circ\text{C}$
T_{stg}	Storage Temperature	-55~+150	$^\circ\text{C}$
TL	Maximum lead temperature for soldering purpose, 1/8" from case for 5 seconds	300	$^\circ\text{C}$

Thermal Characteristics

Symbol	Parameter	Typ.	Max.	Unit
$R_{\theta JC}$	Thermal Resistance, Junction to Case	-	0.88	$^\circ\text{C}/\text{W}$
$R_{\theta JA}$	Thermal Resistance, Junction to Ambient	-	62.5	$^\circ\text{C}/\text{W}$

Electrical Characteristics (Ta=25°C unless otherwise noted)

Symbol	Parameter	Test Condition	Min.	Typ.	Max	Units
Off Characteristics						
BV _{DSS}	Drain-Source Breakdown Voltage	ID=250 μ A, VGS=0	500	--	--	V
ΔBV _{DSS} / ΔT _J	Breakdown Voltage Temperature Coefficient	ID=250 μ A, Reference to 25°C	--	0.55	--	V/°C
IDSS	Zero Gate Voltage Drain Current	Vds=500V, Vgs=0V	--	--	1	μ A
		Vds=400V, Tc=125°C	--	--	10	μ A
IGSSF	Gate-body leakage Current, Forward	Vgs=+30V, Vds=0V	--	--	100	nA
IGSSR	Gate-body leakage Current, Reverse	Vgs=-30V, Vds=0V	--	--	-100	nA
On Characteristics						
V _{GS(th)}	Gate Threshold Voltage	Id=250uA, Vds=Vgs	2	--	4	V
R _{DS(on)}	Static Drain-Source On-Resistance	Id=4.5A, Vgs=10V	--	0.65	0.75	Ω
Dynamic Characteristics						
Ciss	Input Capacitance	VDS=25V, VGS=0, f=1.0MHz	--	1110	--	pF
Coss	Output Capacitance		--	160	--	pF
Crss	Reverse Transfer Capacitance		--	20	--	pF
Switching Characteristics						
Td(on)	Turn-On Delay Time	VDD=250V, ID=9A, RG=25 Ω (Note 3,4)	--	25	60	nS
Tr	Turn-On Rise Time		--	95	200	nS
Td(off)	Turn-Off Delay Time		--	55	120	nS
Tf	Turn-Off Fall Time		--	60	130	nS
Qg	Total Gate Charge	VDS=400, VGS=10V, ID=9A (Note 3,4)	--	28	36	nC
Qgs	Gate-Source Charge		--	7	--	nC
Qgd	Gate-Drain Charge		--	12.5	--	nC
Drain-Source Diode Characteristics and Maximum Ratings						
I _S	Maximun Continuous Drain-Source Diode Forward Current		--	--	9	A
I _{SM}	Maximun Plused Drain-Source Diode Forward Current		--	--	36	A
V _{SD}	Drain-Source Diode Forward Voltage	Id=9A	--	--	1.45	V
trr	Reverse Recovery Time	I _S =9.0A, V _{GS} =0V	--	300	--	nS
Qrr	Reverse Recovery Charge	di _F /dt=100A/μ S (Note3)	--	2.2	--	μ C
*Notes	1, L=8mH, IAS=9A, VDD=50V, RG=25Ω, Starting T _J =25°C 2, Repetitive Rating : Pulse width limited by maximum junction temperature 3, Pulse Test : Pulse Width ≤ 300μs, Duty Cycle ≤ 2% 4, Essentially Independent of Operating Temperature					

Typical Characteristics

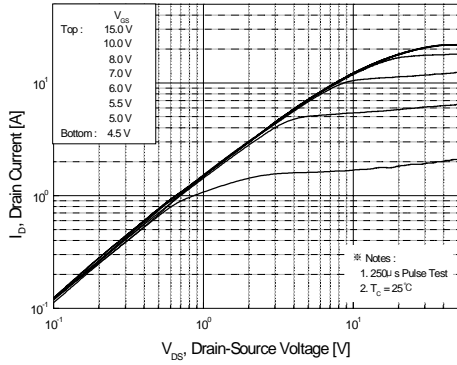

Figure 1. On-Region Characteristics

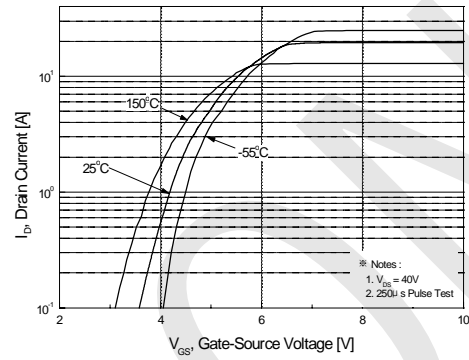

Figure 2. Transfer Characteristics

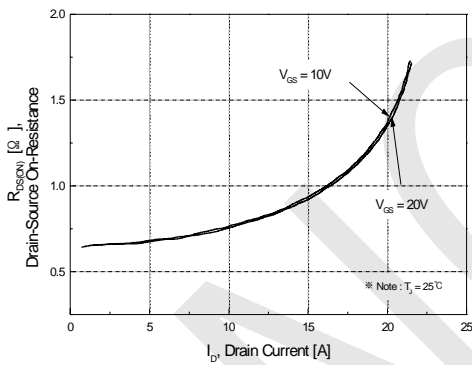

Figure 3. On-Resistance Variation vs. Drain Current and Gate Voltage

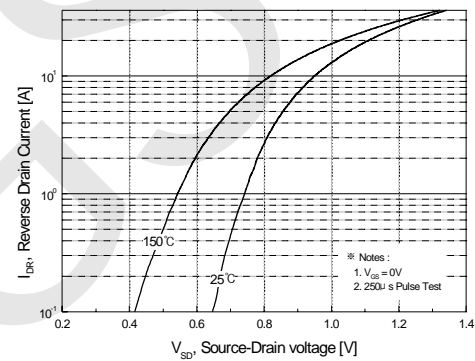

Figure 4. Body Diode Forward Voltage Variation with Source Current and Temperature

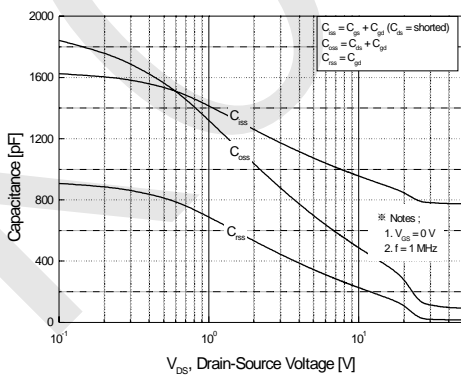

Figure 5. Capacitance Characteristics

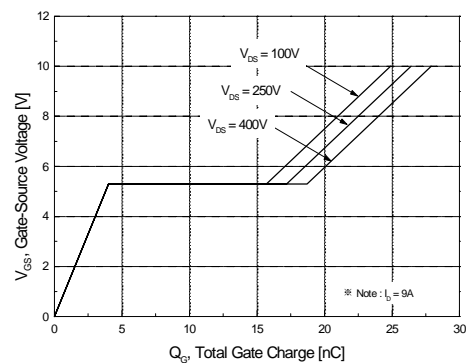

Figure 6. Gate Charge Characteristics

Typical Characteristics (Continued)

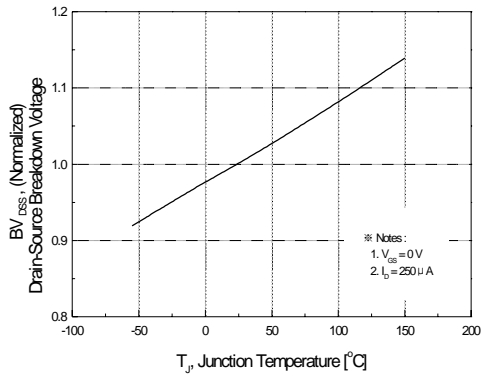

Figure 7. Breakdown Voltage Variation vs Temperature

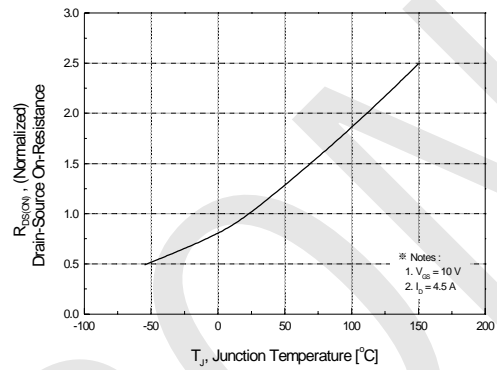

Figure 8. On-Resistance Variation vs Temperature

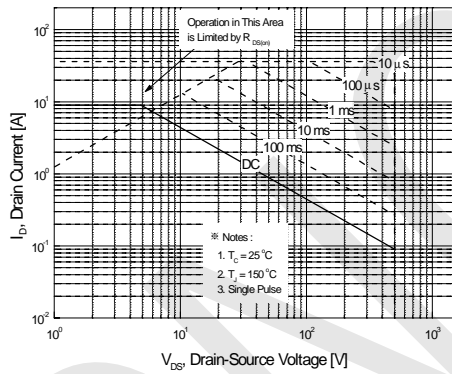

Figure 9-2. Maximum Safe Operating Area

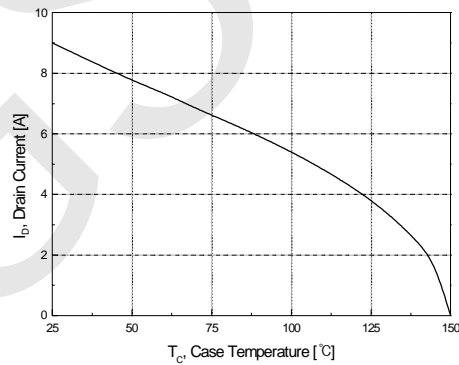

Figure 10. Maximum Drain Current vs Case Temperature

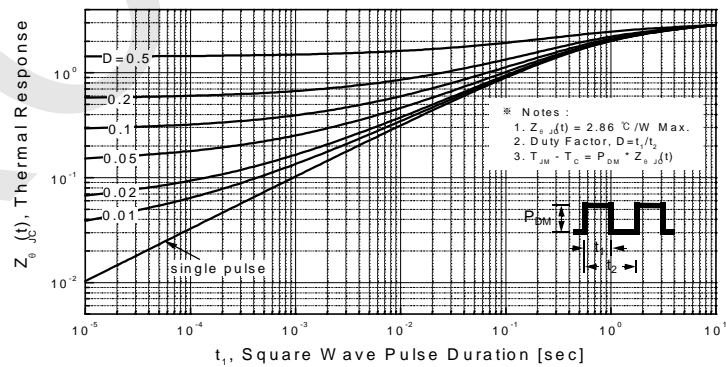
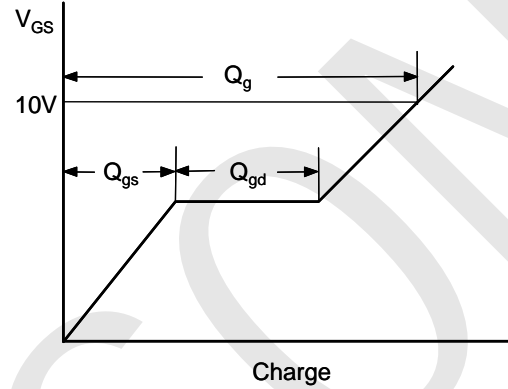
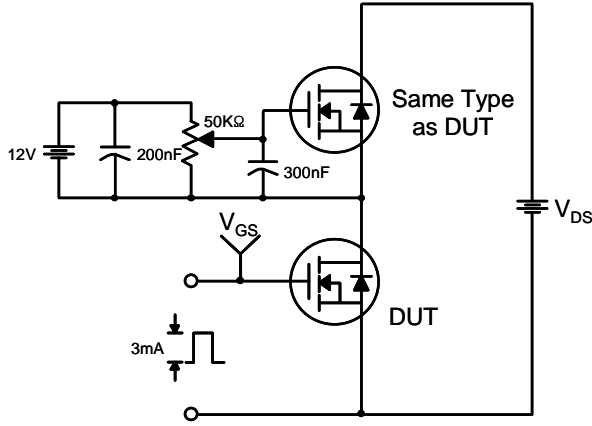
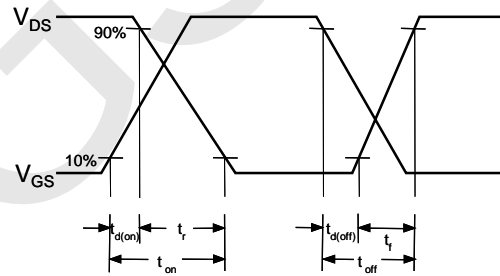
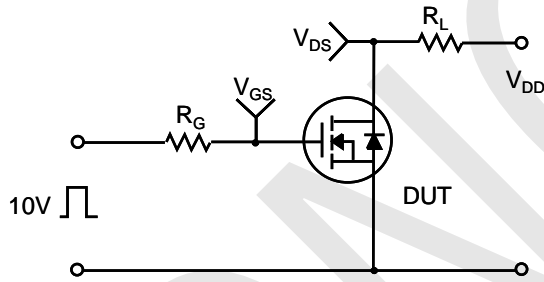

Figure 11-2. Transient Thermal Response Curve

Gate Charge Test Circuit & Waveform



Resistive Switching Test Circuit & Waveforms



Unclamped Inductive Switching Test Circuit & Waveforms

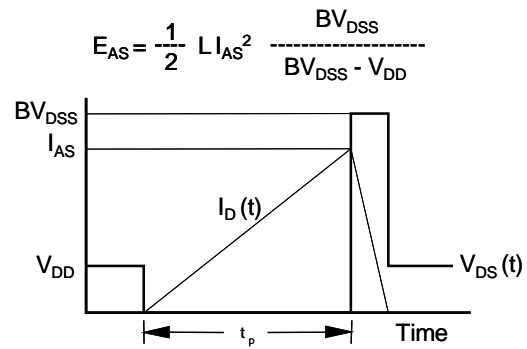
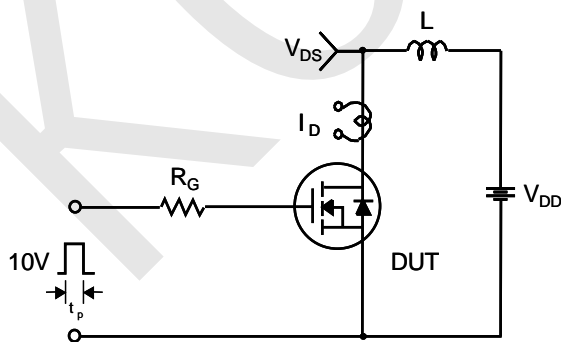

Peak Diode Recovery dv/dt Test Circuit & Waveforms

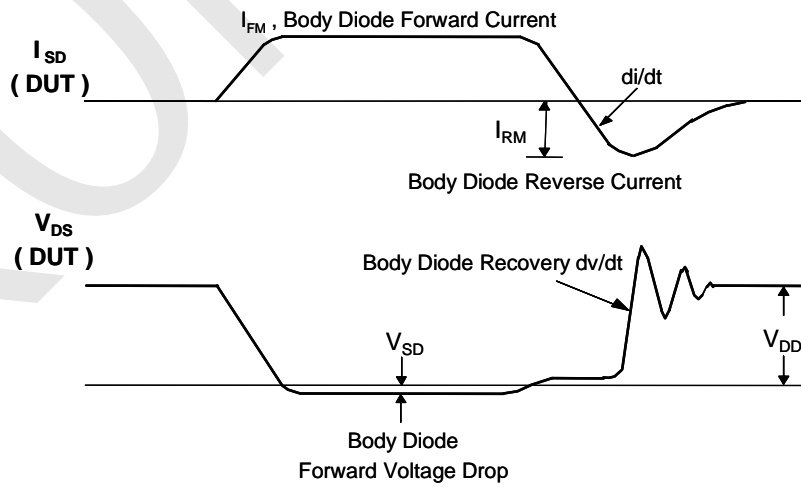
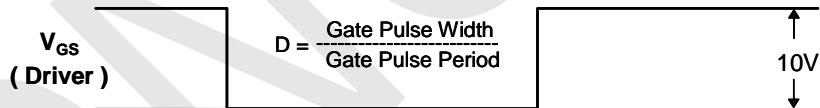
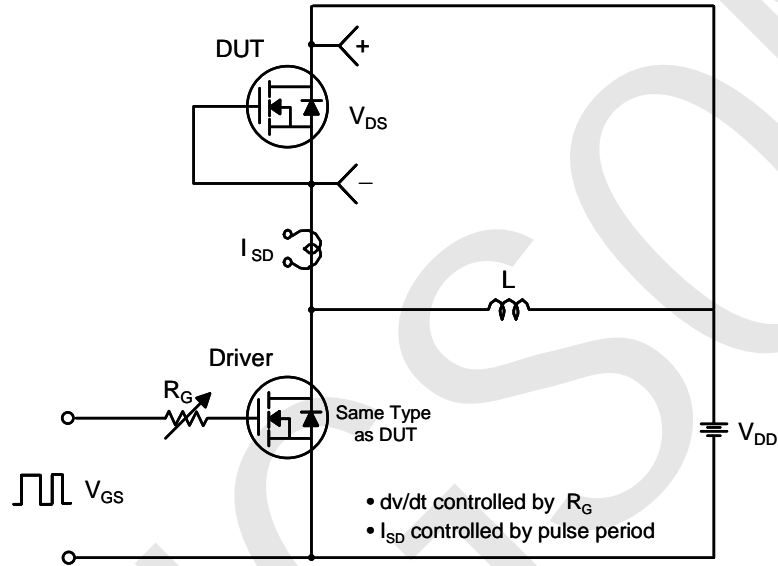

Package Dimension

TO-220

Unit:mm

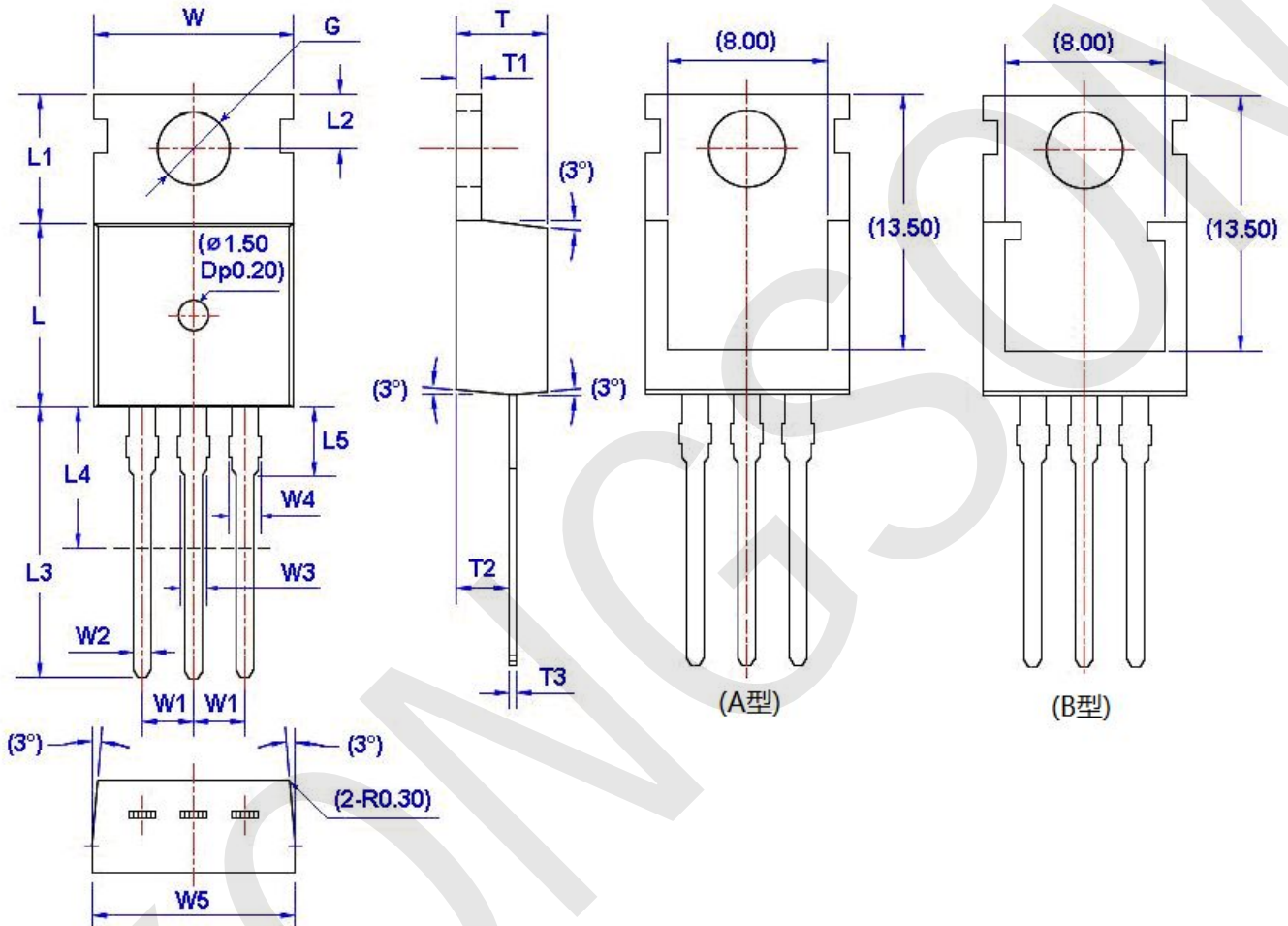

Symbol	Size		Symbol	Size		Symbol	Size		Symbol	Size	
	Min	Max		Min	Max		Min	Max		Min	Max
W	9.66	10.28	W5	9.80	10.20	L4**	6.20	6.60	T3	0.45	0.60
W1	2.54 (TYP)		L	9.00	9.40	L5	2.79	3.30	G(Φ)	3.50	3.70
W2	0.70	0.95	L1	6.40	6.80	T	4.30	4.70			
W3	1.17	1.37	L2	2.70	2.90	T1	1.15	1.40			
W4*	1.32	1.72	L3	12.70	14.27	T2	2.20	2.60			