



One-Chip Solution Power Bank PMIC

General Description

The VAS5180 is optimized for power bank application; it is a single chip solution PMIC with fully covers charger, boost converter, fuel gauge, torch light and output short protection functions. A high efficiency SW charger offers max. 2.5A charger current with adjustable cell voltage and safety timer, it also integrated both input current limit and input voltage regulation to manage max input power without DC source crash. A boost converter support 5V/2A output and designed to allow true output disconnect, the automatic load-in enable and load remove disable provide convenience of use. The VAS5180 integrate all power switches, minimizes external components, simplify application, require no MCU and share one inductor for both charger and boost mode, all of these make it is the most BOM efficient compare with present power bank solutions.

Features(Charger)

- Integrated power MOSFETs
- 20V input rating (surge protection)
- Real ONE chip solution, no MCU required
- Programmable up to 2.5A charge current(set by ext. R1SET resistor)
- Up to 94% efficiency
- Programmable output voltage (4.20V to 4.4V) with $\pm 1\%$ accuracy
- Automatically reduce charge current when supplied by poor power source (VIN-DPM)
- Does not required reverse blocking diode or MOS
- No sense resistor required
- Integrated fuel gauge and capacity indicator
- Fault indicator
- $\pm 10\%$ charge current accuracy
- 1.5MHz operating frequency to minimize external components size
- Protections:
 - VIN 6.7V OVP protection (stop switching)
 - Programmable safety timer(3~20 hours)
 - Thermal regulation / OTP shutdown
 - Cell temperature qualification
- Disconnect USB-A port when charging

Features(Boost)

- Low standby current < 30uA
- Share charger inductor (2.2 or 3.3uH)
- Capable of outputting 5V/2.2A with 3.1V battery
- Up to 90% efficiency
- 3.15V low battery automatic off
- 2.9V under-voltage lockout
- 1.5MHz operating frequency
- Adjustable output voltage form 5.0~5.4V with $\pm 1.5\%$ accuracy
- Internal compensation and soft start
- Fast transient response with a 10uF MLCC and one 100uF electrolytic or Tantalum capacitor
- Integrate torch light driver (50mA)
- Integrate battery fuel gauge and LED indication
- Automatically shut down when no load
- Automatically enable if load detected
- Multi-protections:
 - Cycle-by-cycle 6A current limit
 - OTP shutdown
 - 2.5A max. Iout clamp
 - Output over-load /short protection. (disconnect USB-A port, no protector IC required)
 - Disconnect Micro-USB port when dis-charging
- TQFN4x4-24 and TSSOP-24 (EP) package

Applications

- Power Bank for Tablet, Mobile Phone and MID



Typical Application Circuits

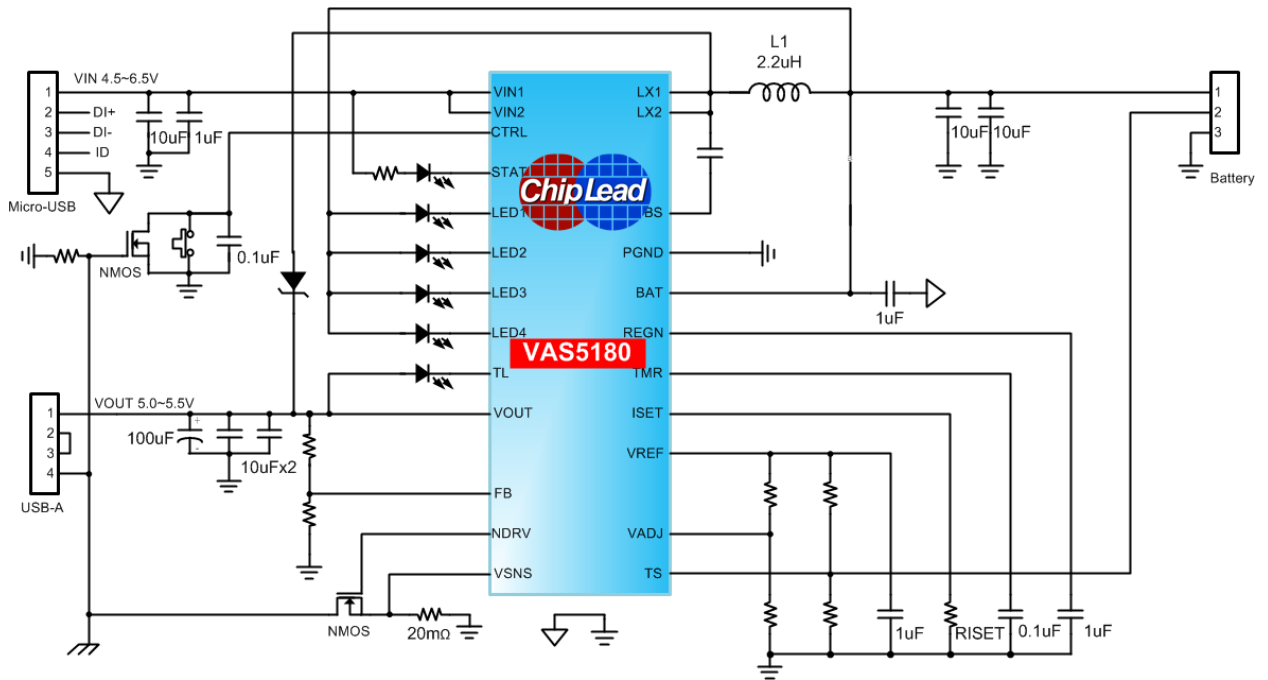

Figure 1. Typical Application Schematic

Function Block Diagram

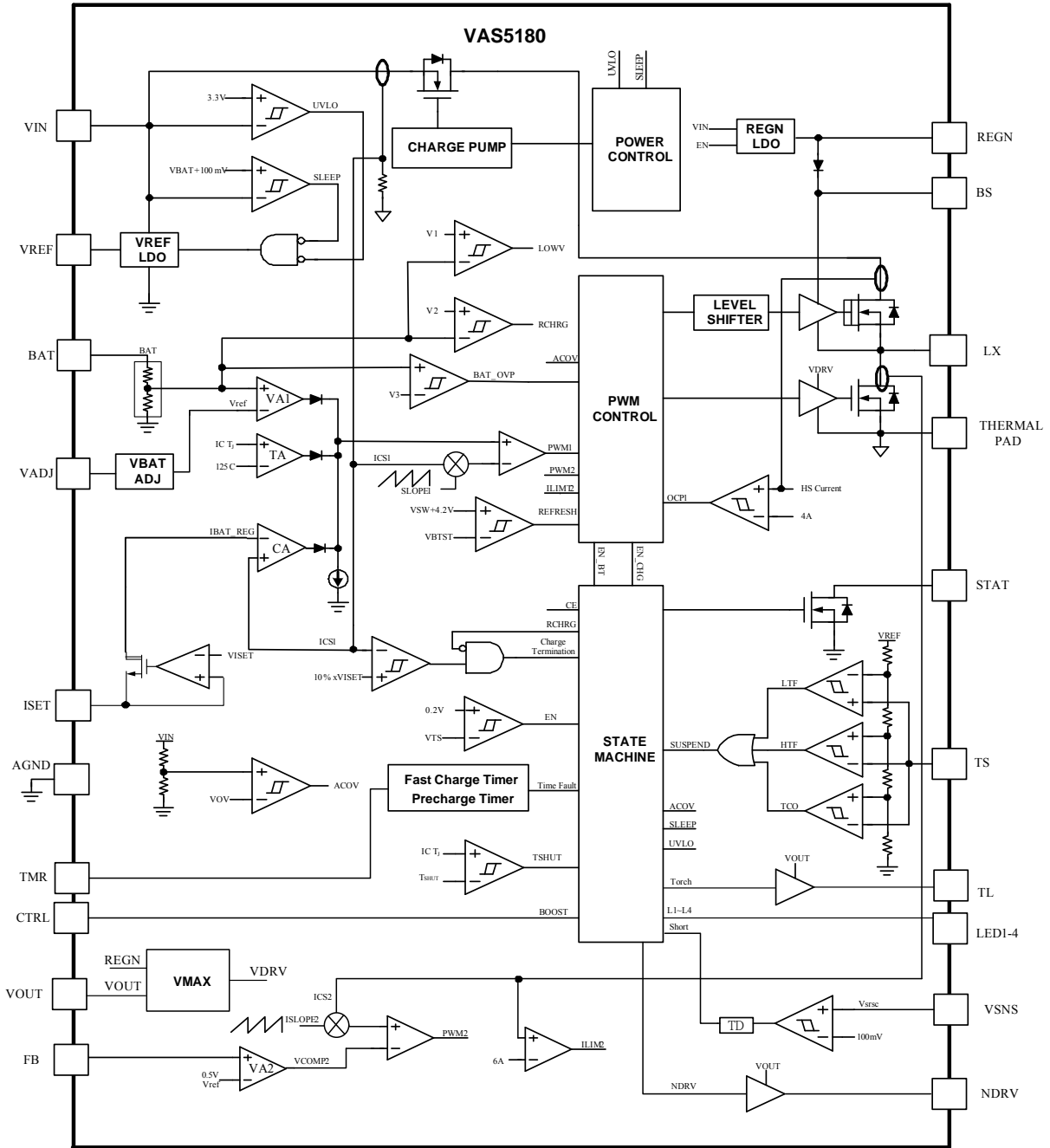

Figure 2. Function Block Diagram



PIN Configuration

Package	PIN-OUT
QFN-24	
TSSOP-24(EP)	



PIN Description

TQFN PIN NO.	TSSOP PIN NO.	Name	Description		
1, 24	1,2	VIN	IC power supply of power device of Charger. Put 22uF MLCC from VIN to PGND.		
2	3	BS	Bootstrap pin. Place a 0.047u-F MLCC from LX to BS		
3	4	VREF	3.3V reference output. A 1uF MLCC is placed from VREF to GND to make it stable.		
4	5	TS	NTC resistor connection. Cell temperature qualification input pin.		
5	6	VADJ	Set VADJ voltage between 0V~VREF to adjust charge regulation voltage (4.2~4.4V).		
6	7	ISET	Fast charge current set pin.		
7	8	TMR	Connect a capacitor from this node to AGND to set the fast charge safety timer. (5.6min/1nF)		
8	9	STAT	Open drain output		
			Hi-Z	Low	Blinking
			Charge complete or Sleep mode	Charging in progress	Fault
9,10, 11,12	10,11, 12,13	LED1-4	LED indicator for report battery capacitance.		
13	14	TL	50mA Torchlight LED driver output.		
14	15	VSNS	USB-A port ground path (low side) current sense input.		
15	16	NDRV	N-ch MOSFET gate driver output. NDRV turn N-ch MOSFET off when VSNS detect over-current and auto-recovery turn on once short circuit removed.		
16	17	FB	Boost output voltage feedback adjustment. Connect the output of a resistor divider powered from the boost output VOUT to FB to AGND.		
17	18	VOUT	Async. Boost output. A 10uF MLCC and one 100uF electrolytic capacitor are placed from VOUT to PGND.		
18	19	BAT	Charger voltage regulation sense input.		
19	20	PGND	Power ground.		
20	21	REGN	5V power supply output, Bypass 1u-F MLCC to AGND.		
21	22	CTRL	Boost mode enable and battery capacitance report control input.		
22, 23	23,24	LX	Switching node, charge current output inductor connection. Connect a 47-nF BS capacitor from LX to BS.		



Order Information

Order Number	Package Type	QTY/Reel	Green Status	Operation temp range
VAS5180IJ24E	QFN24	2500	RoHS	-40 °C to 85°C

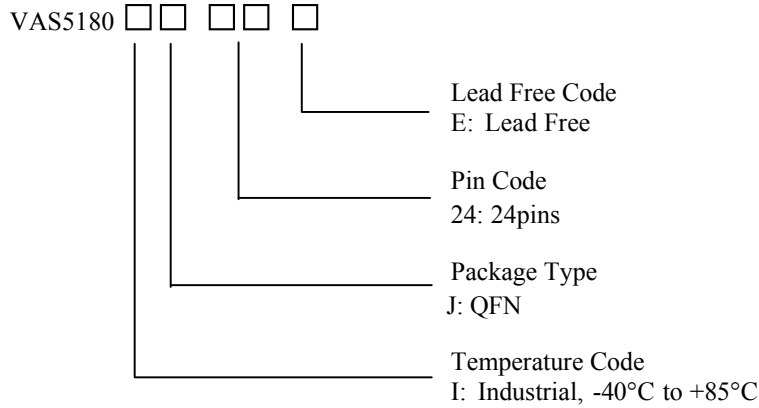

Absolute Maximum Ratings

Parameters	Maximum Ratings
VIN, BS, STAT	-0.3V to 20V
LX	-2V to 7V
REGN, TMR, VOUT, BAT, CTRL, LED1, LED2, LED3, LED4, TL, FB, NDRV, VSNS, ISET	-0.3V to 7V
VREF, VADJ, TS	-0.3V to 3.6V
PGND	-0.3V to +0.3V
Junction temperature range	-40°C to +150°C
Storage temperature range	-65°C to +150°C
Lead Temperature	260°C
Maximum Power Dissipation	2W
ESD (HBM)	2000V



Electrical Characteristics

PARAMETERS		TEST CONDITIONS	MIN	TYP	MAX	UNITS
OPERATING CONDITIONS						
V _{VIN_OP}	VIN input voltage operating range during charging.		4.5		6	V
QUIESCENT CURRENT						
I _{IN}	Adapter supply current	VIN=5V		1.5	2	mA
I _{BAT}	Battery discharge current	VBAT=4.2V, standby mode		15	30	μA
CHARGE VOLTAGE REGULATION						
V _{BAT_REG}	BAT regulation voltage	Measured on BAT		4.2		V
	Charge voltage regulation accuracy	TJ = -20°C to 85°C	-1%		1%	
V _{VADJ}	VADJ voltage range		0		VREF	V
V _{BAT_ADJ}	Regulation voltage Adjustment	VADJ=0V,		4.2		V
		VADJ=1/2*VREF		4.3		V
		VADJ=VREF		4.41		V
CURRENT REGULATION						
I _{CHG}	Fast charge current	Programmable Mode(Max)		2.0	2.5	A
V _{ISET}	Fast charge current reference voltage			1.0		V
	Output “fast charge” formula	V _{BAT_REG} > V _{BAT} > V _{LOWV} ; ISET2=FLOAT RISET = 30kΩ to 200kΩ		KISET/ RISET		A
K _{ISET}	Fast charge current factor	RISET = KISET /IOUT ; 500<IOUT< 2500mA	75	80	85	AkΩ
CURRENT REGULATION –PRE- CHARGE						
%PRECHG	Pre-charge current, default setting	V _{BAT} < V _{LOWV}		10		%IOUT-CC
CHARGE TERMINATION						
%TERM	Termination threshold current, default setting	V _{BAT} > V _{RECHG}	5	10	15	%IOUT-CC
t _{TERM_DEG}	Deglintch time termination (both edges)	V _{BAT} > V _{RECHG} and I _{CHG} < I _{TERM}		100		ms
BAT LOWV COMPARATOR						
V _{LOWV}	Precharge to fast charge transition threshold	Measured on BAT	2.85	2.9	2.95	V
RECHARGE COMPARATOR						
V _{RECHG}	Recharge threshold, below regulation voltage limit, V _{BAT_REG} -V _{BAT}	Measured on BAT	70	100	130	mV



PARAMETERS		TEST CONDITIONS	MIN	TYP	MAX	UNITS
BAT OVER-VOLTAGE COMPARATOR						
V_{OV_RISE}	Battery over-voltage rising threshold	As percentage of V_{BAT_REG}		110		%
V_{OV_FALL}	Battery over-voltage falling threshold	As percentage of V_{BAT_REG}		105		%
INPUT OVER-VOLTAGE COMPARATOR (ACOV)						
V_{ACOV}	AC over-voltage rising threshold to disable charge	VIN rising	6.4	6.6	6.8	V
V_{ACOV_HYS}	AC over-voltage falling hysteresis	VIN falling		300		mV
Input Under-Voltage Lock-Out Comparator (UVLO)						
V_{UVLO}	AC under-voltage rising	Measure on VIN		3.3		V
V_{UVLO_HSY}	AC under-voltage hysteresis	Measure on VIN		300		mV
THERMAL REGULATION						
T_{J_REG}	Junction temperature regulation	Charging		125		°C
THERMAL SHUTDOWN COMPARATOR						
T_{SHUT}	Thermal shutdown temperature	Temperature rising		155		°C
THERMISTOR COMPARATOR						
V_{LTF}	Cold temperature threshold, TS pin voltage rising threshold	Charger suspends charge. As percentage to V_{VREF}	72.5	73.5	74.5	%
V_{LTF_HYS}	Cold temperature hysteresis, TS pin voltage falling threshold	As percentage to V_{VREF}	0.2	0.4	0.6	%
V_{HTF}	Hot temperature TS pin voltage falling threshold	As percentage to V_{VREF}	46.6	47.2	48.8	%
V_{TCO}	Cut-off temperature TS pin voltage falling threshold	As percentage to V_{VREF}	44.2	44.7	45.2	%
VREF REGULATOR						
V_{VREF}	REF regulator voltage	$V_{VIN} > V_{UVLO}$, No load	3.15	3.3	3.45	V
I_{VREF_LIM}	REF current limit	$V_{VREF} = 0\text{ V}$, $V_{VIN} > V_{UVLO}$		40		mA
REGN REGULATOR						
V_{REGN_REG}	REGN regulator voltage	$V_{VIN} > 10\text{ V}$	4.3	4.6	4.9	V
I_{REGN_LIM}	REGN current limit	$V_{REGN} = 0\text{ V}$, $V_{VIN} > 10\text{ V}$		50		mA
INTERNAL PWM						
F_{SW_CHG}	PWM Switching Frequency	Measure at LX	1200	1400	1600	kHz



PARAMETERS		TEST CONDITIONS	MIN	TYP	MAX	UNITS
R _{DS_HI}	High Side MOSFET On Resistance			80	120	mΩ
R _{DS_LO}	Low Side MOSFET On Resistance			40	60	mΩ
R _{DS_BD}	Block MOSFET On Resistance			50	70	mΩ
SAFETY TIMER						
T _{PRE-CHARGE}	Pre-charge timer		1848	2100	2352	Sec
T _{FAST-CHARGE}	Fast-charge timer	T _{CHG} =C _{TMR} *K _{TMR}	1		15	hr
K _{TMR}	Timer Multiplier			5.6		min/nF
DC/DC STAGE						
V _I	Input voltage range	VBAT input voltage	3.0		4.5	V
V _{OUT}	Output voltage range		4.5		5.5	V
V _{FB}	Feedback voltage		980	1000	1020	mV
f _{SW}	Oscillator frequency		1200		1600	kHz
I _{SW_LIM}	Switch current limit	VOUT= 5 V	5000	5500	6000	mA
R _{SW_ON}	Switch on resistance	VOUT= 5 V		30	50	mΩ
I _{STDBY}	Standby current	VBAT = 4.2 V, Boost off		15	30	μA
CONTROL STAGE						
V _{BATUVLO}	Under voltage lockout threshold	VBAT voltage decreasing		2.9		V
V _{BATLOW}	Battery low to boost enter standby mode	VBAT voltage decreasing	3.05	3.1	3.15	V
T _{LOW_FLASH}	Battery low, LED1 flash period	VBAT<V _{BATLOW} , LED1 start flash to LED1 turn off	4	6	8	Sec
F _{LOW_FLASH}	Battery low, LED1 flash frequency	VBAT<V _{BATLOW} , LED1 start flash frequency	1.2	1.4	1.6	Hz
V _{SNS}	Overload detection threshold	Measure VSNS to GND	90	100	110	mV
t _{VSNS_DEG}	VSNS detection deglitch time	VSNS> 100mV to NDRV turn off		20		μS
V _{NDRV_OL}	NDRV output low voltage				0.1	V
V _{NDRV_HI}	NDRV output high voltage		VOUT -0.1			V
V _{IL}	CTRL logic low threshold		0.4			V
V _{IH}	CTRL logic high threshold				1.4	V
t _{CTRL_DEG}	CTRL logic low deglitch time			100		μS
V _{LED_OL}	LEDs output low voltage	LEDs sink 1mA			1	V



PARAMETERS		TEST CONDITIONS	MIN	TYP	MAX	UNITS
F _{LED_CHG}	LEDs wave frequency at charge mode	LED N-1 to N switch frequency	1.2	1.4	1.6	Hz
T _{LED_HOLD}	Gauge on hold time at boost mode	CTRL goes low, LEDs on to LEDs off	4	6	8	Sec
T _{MANUALOFF}	CTRL cont. low to boost enter standby mode deglitch	CTRL goes cont. low to boost turn off	4	6	8	Sec
T _{TL_EN}	Effective interval for two CTRL low pulses to enable or disable torch light		1.2	1.7	2	Sec
I _{TL_LIM}	TL sink current limit	Torch light on, V _{TL} =2V		50		mA
T _{LEDOFF}	No load to LEDs off delay	No load to gauge LEDs turn off	4	6	8	Sec
T _{NOLOADOFF}	No load to Boost off delay	No load to Boost turn off	1.5	1.8	2	min

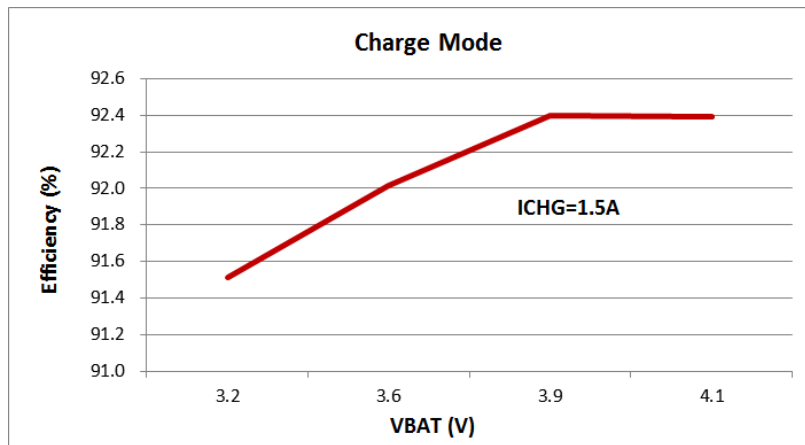

Figure 3. VIN=5.0V, 1.5A Charge Efficiency vs. VBAT

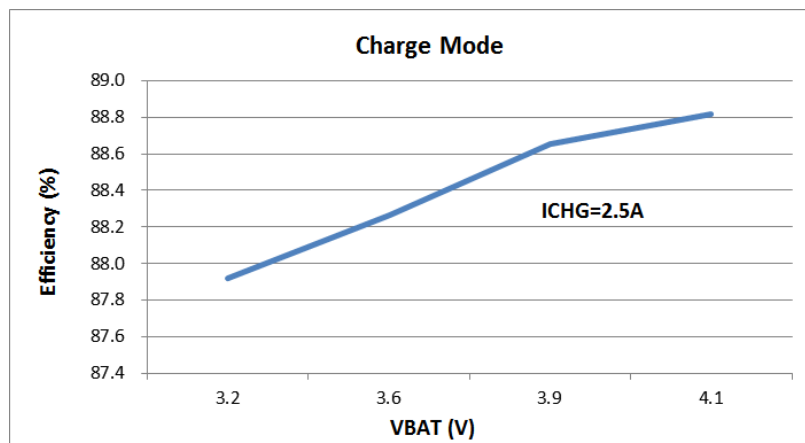

Figure 4. VIN=5.0V, 2.5A Charge Efficiency vs. VBAT

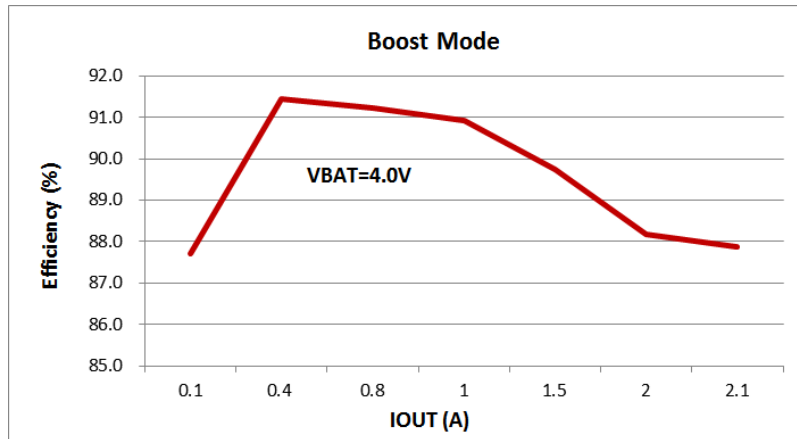

Figure 5. VOUT=5.0V, VBAT=4.0V, Boost Efficiency vs. IOU T

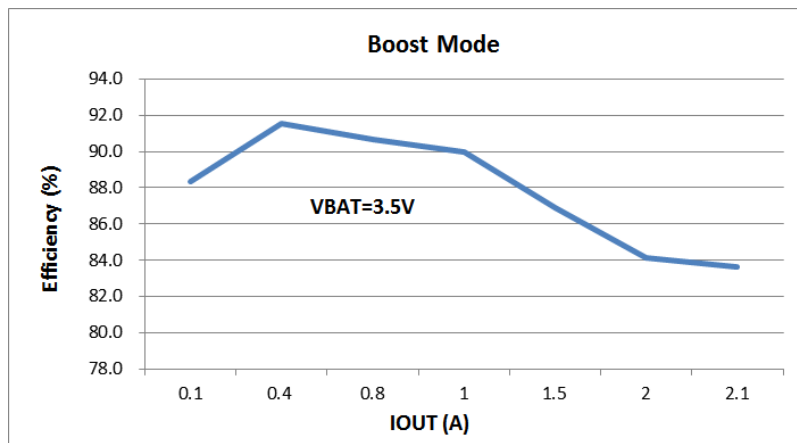

Figure 6. VOUT=5.0V, VBAT=3.5V, Boost Efficiency vs. IOU T

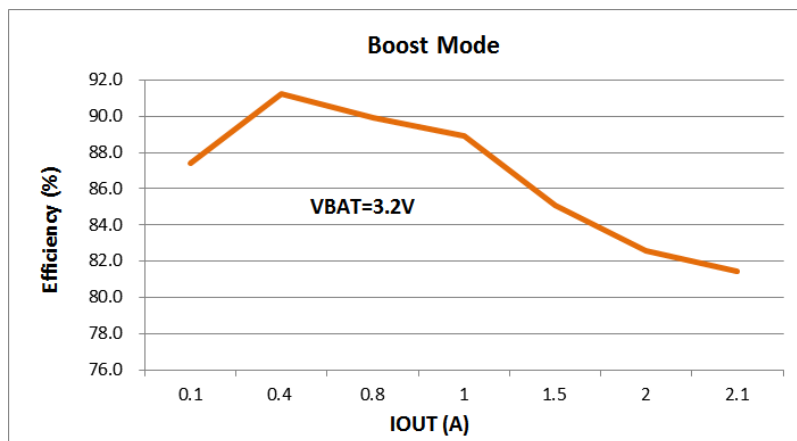

Figure 7. VOUT=5.0V, VBAT=3.2V, Boost Efficiency vs. IOU T

Operation State Diagram

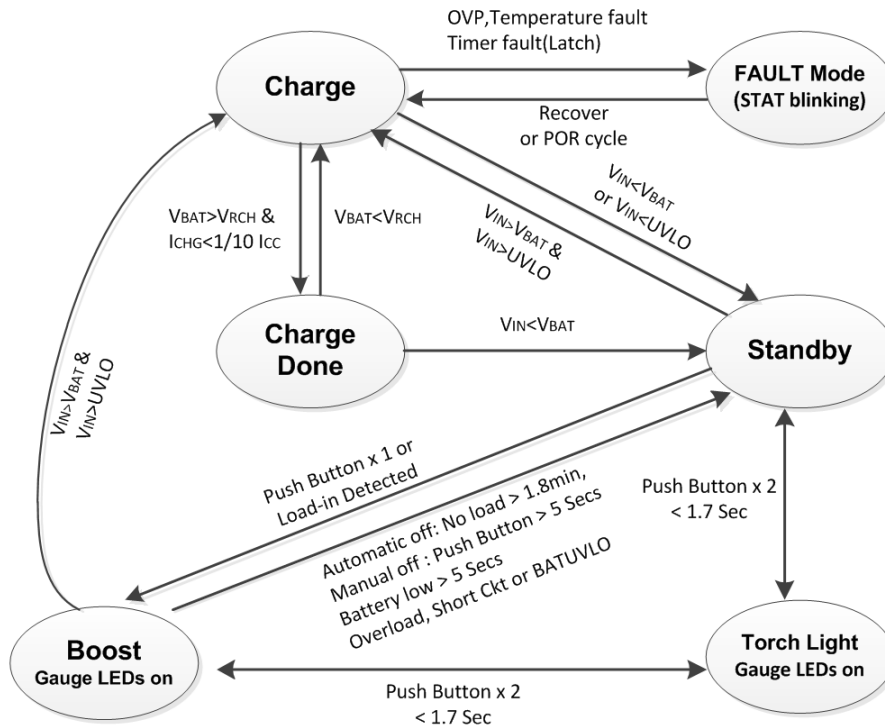

Figure 8. State Diagram

Gauge Light Indication

Mode	VBAT	LED1	LED2	LED3	LED4	STAT
CHARGE	BAT < 3.7V	WAVE	WAVE	WAVE	WAVE	ON
	3.7V < BAT < 3.85V	ON	WAVE	WAVE	WAVE	ON
	3.85V < BAT < 4.15V	ON	ON	WAVE	WAVE	ON
	4.15V < BAT	ON	ON	ON	WAVE	ON
	Termination	ON	ON	ON	ON	OFF
BOOST	BAT < 3.15V	Blink 6 secs then OFF	OFF	OFF	OFF	OFF
	3.15V < BAT < 3.55V	ON	OFF	OFF	OFF	OFF
	3.55V < BAT < 3.76V	ON	ON	OFF	OFF	OFF
	3.76V < BAT < 4.02V	ON	ON	ON	OFF	OFF
	4.02V < BAT	ON	ON	ON	ON	OFF
STANDBY		OFF	OFF	OFF	OFF	OFF



CTRL Control

<i>Mode</i>	<i>Function</i>	<i>One pulse</i>	<i>Double pulse <1.7sec</i>	<i>One more pulse during Torch ON</i>	<i>Pulse> 5Sec during Boost ON</i>
CHARGE	<i>BOOST</i>	OFF			
	<i>GAUGE</i>	ON			
	<i>TORCH</i>	OFF			
	<i>NDRV ON</i>	OFF			
BOOST <i>VBAT>2.9V</i> <i>VIN<VBAT</i>	<i>BOOST</i>	ON Keep 1.8mins ON then OFF (no load)	ON	ON	OFF
	<i>GAUGE</i>	ON(load) Keep 6sec ON then OFF(no load)	ON (Torch EN)	ON (Torch OFF)	OFF
	<i>TORCH</i>	OFF	ON or OFF	Delay 1.7sec then OFF	OFF
	<i>NDRV ON</i>	ON	ON	ON	OFF

- CTRL key has no function during charging mode, the boost converter is off and the load (USB-A) is disconnected from battery power.
- In standby mode, click the CTRL button can start the BOOST and battery power indicator, such as the no-load input, the power indicator off after 6 seconds, BOOST to turn off automatically after 1.8 minutes.
- If battery voltage is between 2.9V ~ 3.15V, click the button, battery indicator LED1 flashes and go back to standby mode after 6 seconds.
- If battery voltage is lower than 2.9V, click the button will not weak BOOST up, the power bank keep stay at the standby mode.
- Double-click the button to turn on or off the flashlight, and power display always on when flashlight function is activated, in this mode, click the button again, flashlight off automatically after 1.7 seconds delay.
- In boost mode, press button 5 seconds, you can manually turn off BOOST, and disconnect the load circuit.

Application Information

◆ Charge Management

1. Typical Operation Theory

The charger of VAS5180 is optimized for charging 1-cell Li-ion or Li-polymer batteries. It charges a battery with constant current (CC) and constant voltage (CV) profile. In CV mode, if charge current reaches 1/10 constant current threshold, fuel gauge 4 LEDs are turned on. The typical charge profile is illustrated as below.

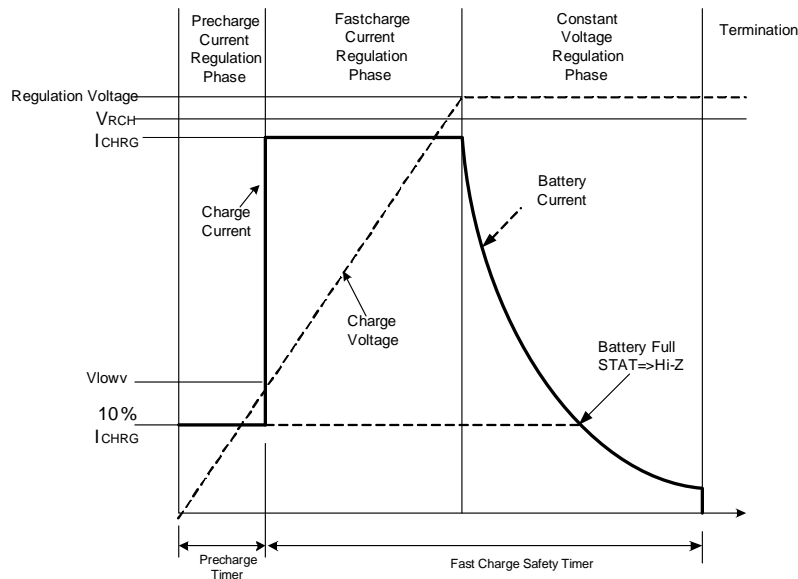

Figure 9. Typical Charging Profile

2. Battery Voltage Regulation

The VAS5180 offers a high accuracy voltage regulator for the charging voltage. Battery regulation voltage could be adjusted by setting VADJ voltage and the equation for the adjustment is:

$$V_{BAT_REG} = \left[\left(\frac{V_{ADJ}}{V_{REF} \cdot 20} + 1 \right) \times 4.2 \right]$$

3. Battery Current Regulation

The ISET input sets the maximum charging current. The equation for charge current is:

$$I_{CHG} = \frac{1}{R_{ISET}} \times 80K$$

Give a 40kΩ RISET to set 2A charge current, for instance. Under high ambient temperature, the charge current will fold back to keep IC temperature not exceeding 125°C.

4. Battery Pre-charge Current Regulation

If the battery voltage is below the VLOWV threshold, the VAS5180 applies the pre-charge current to the battery. This pre-charge feature is intended to revive deeply discharged cells. If the VLOWV threshold is not reached within 30 minutes of initiating pre-charge, the charger turns off and a FAULT is indicated on the status pins.

For VAS5180, the pre-charge current is set as 10% of the fast charge rate.

5. Input Over Voltage Protection

Input OVP provides protection to prevent device damage due to high input voltage. The threshold of input OVP is 6.7V typ., once input above threshold, the charger is disabled and STAT indicated FAULT.

6. Input Voltage Regulation

The input voltage can be limited in order to avoid overloading of DC adapter or USB power source, when the voltage on VIN pin drops and hits the threshold voltage of 4.7V, the charging current will be decreased and input voltage will be clamped to this value.

7. Charge Termination

The charger monitors the charging current during the voltage regulation phase. Termination is detected when the charge taper down to 1/10 of the fast charge rate.

8. Re-Charge

A new charge cycle is initiated when one of the following conditions occurs:

- The battery voltage falls below the recharge threshold
- A power-on-reset (POR) event occurs

9. Safety Timers

As a safety backup, the charger also provides an internal fixed 35 minutes pre-charge safety timer and programmable fast charge timer according to the capacitor value which connected to TMR pin.

10. Soft-Start Charger Current

The charger automatically soft-starts the charger regulation current every time the charger goes into fast-charge to ensure there is no overshoot or stress on the output capacitors or the power converter.

11. Temperature Qualification

The controller continuously monitors battery temperature by measuring the voltage between the TS pin and AGND. A negative temperature coefficient thermistor (NTC) and an external voltage divider typically develop this voltage. The controller compares this voltage against its internal thresholds to determine if charging is allowed. To initiate a charge cycle, the battery temperature must be within the VLTF to VHTF thresholds. If battery temperature is outside of this range, the controller suspends charge and waits until the battery temperature is within the VLTF to VHTF range. During the charge cycle the battery temperature must be within the VLTF to VTCO thresholds. If battery

temperature is outside of this range, the controller suspends charge and waits until the battery temperature is within the VLTF to VHTF range. The controller suspends charge by turning off the PWM charge MOSFETs.

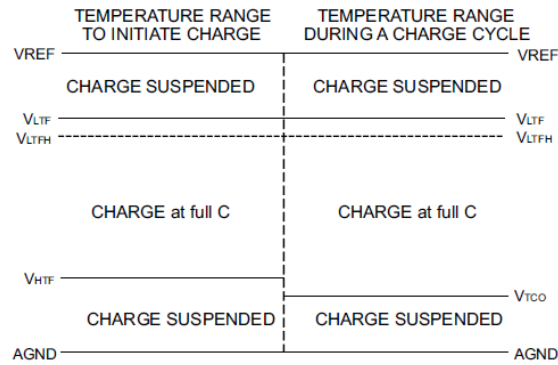

Figure 10. TS Pin, Thermistor Sense Threshold

Assuming a NTC thermistor on the battery pack have resistance at 0°C and 45°C are RTH_{COLD} and RTH_{HOT} , the values of $RT1$ and $RT2$ can be determined by using below equations.

$$RT2 = \frac{V_{REF} \times RTH_{COLD} \times RTH_{HOT} \times \left(\frac{1}{V_{LTF}} - \frac{1}{V_{TCO}} \right)}{RTH_{HOT} \times \left(\frac{V_{REF}}{V_{TCO}} - 1 \right) - RTH_{COLD} \times \left(\frac{V_{REF}}{V_{LTF}} - 1 \right)}$$

$$RT1 = \frac{\frac{V_{REF}}{V_{LTF}} - 1}{\frac{1}{RT2} + \frac{1}{RTH_{COLD}}}$$

◆ Boost Converter

1. Typical Operation Theory

The VAS5180 integrates a boost converter powered by a one-cell Li-Ion or Li-polymer battery. The converter generates a stable output voltage that is either adjusted by an external resistor divider. The typical value of the voltage on the FB pin is 1.0V. The maximum allowed value for the output voltage is 5.5 V. It provides high efficient power conversion and is capable of delivering output currents up to 2 A at 5 V at a supply voltage down to 2.9 V. The implemented boost converter is based on a fixed frequency, pulse-width- modulation (PWM) controller. The maximum peak current in the boost switch is limited to a value of 5.5A, an internal temperature sensor prevents the device from getting overheated in case of excessive power dissipation.

2. Soft Start



The boost automatically soft-starts the switching current to load to ensure there is no overshoot or inrush stress on the output capacitors, the boost switch current limit is set to 50% of its normal value to avoid high peak current at battery during soft-start period. When the output voltage is reached, the voltage regulator takes control and switch current limit is set back to 100%.

3. Over-current and Short Protection

The peak current of the low switch is sensed to limit the maximum current flowing through the switch and the inductor. The typical cycle by cycle peak current limit is set to 5.5A. The NDRV is used to control an external NMOSFET to connect the output of converter to load (USB-A) or not and VSNS pin is used to monitors output current through a low-side sense resistor. The NDRV turn NMOS on if soft-start completed, and will turn NMOS off if boost output voltage fall below to battery voltage due to average overloading or short current detected at VSNS pin. As ext. NMOS is switched off, the load (USB-A) is isolated from boost output. The detection threshold of VSNS is set to 100mV with 20us deglitch.

4. Automatic Load-in Detection

Design an external resistor connect USB-A ground to system ground, when a load is connected to USB-A port, the load and ext. resistor construct a resistor divider from VOUT to ground. If the resistance of load is small enough to pull divided voltage high and turn on NMOS, the CTRL could be pulled low to enable boost converter. For example, set ext. resistor to 100k Ω , and a load with less than 200k Ω resistance is connected, the divided voltage from a 3.0V VOUT can as high as 1.0V and be able to turn a NMOS on.

5. Light Load Automatic Shutdown

The boost converter detects average current to load, if average current fall below 20mA for 5sec., the fuel gauge LEDs are turning off and start 1.8min go standby timer. Once 1.8mins timer expired, and average current never go back above 20mA, then the boost enter automatic shutdown.

◆ Fuel Gauge LEDs Indication

The VAS5180 integrated with four LED constant current drive ports for intelligent battery level indication, the chip built-in state lock function to prevent indicate the status of instability. See “Gauge Light Indication” table for detail fuel gauge level and LEDs behavior.



Tape and Reel Information

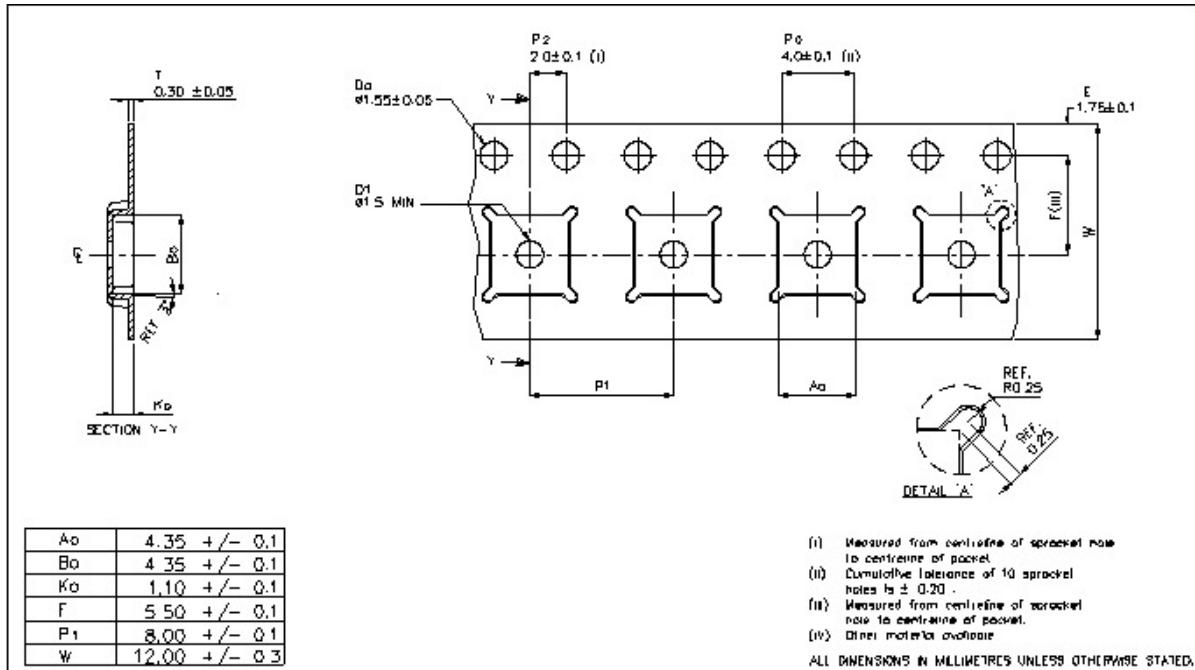



Package Information

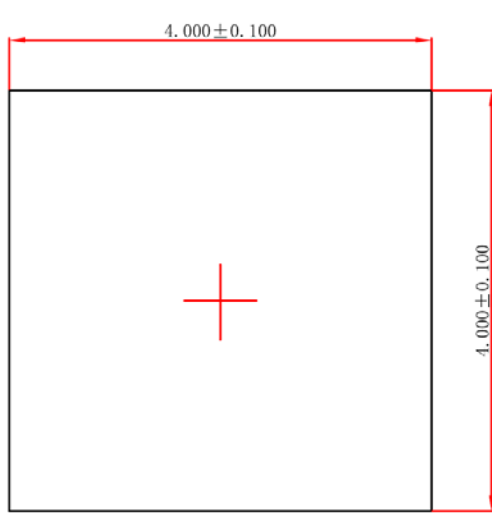

Top View

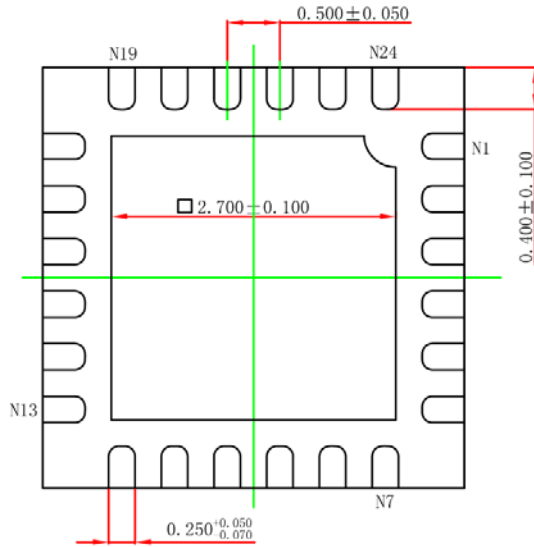

Bottom View

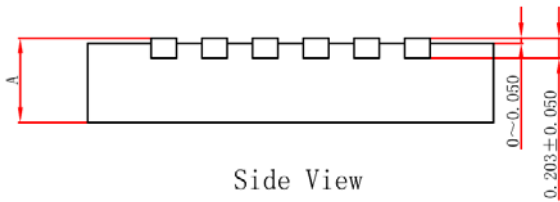

Side View

	MIN.	NORM.	MAX.
A	0.700	0.750	0.800
	0.800	0.850	0.900

Classification Reflow Profiles

Profile Feature	Pb-Free Assembly
Preheat & Soak Temperature min (T _{smin}) Temperature max (T _{smax})	150°C
Time (T _{smin} to T _{smax}) (t _s)	200°C 60-120 seconds
Average ramp-up rate (T _{smax} to T _p)	3°C/second max.
Liquidous temperature (T _L)	217°C
Time at liquidous (t _L)	60-150 seconds
Peak package body temperature (T _p)*	Max 260°C
Time (t _p)** within 5°C of the specified classification temperature (T _c)	Max 30 seconds
Average ramp-down rate (T _p to T _{smax})	6°C/second max.
Time 25°C to peak temperature	8 minutes max.

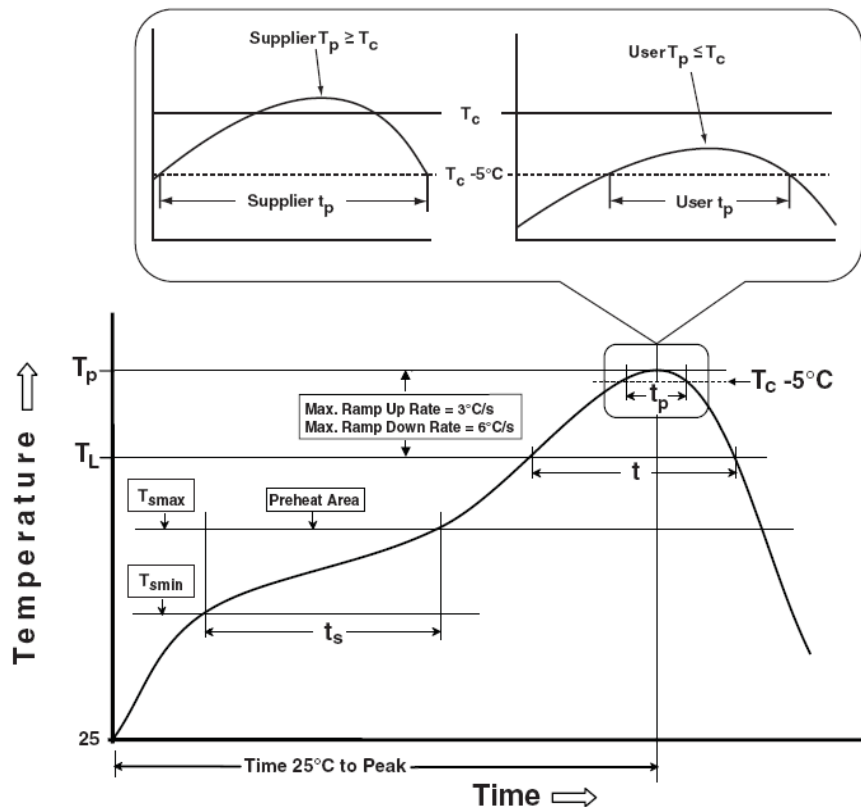

Figure 21. Classification Profile



CAUTION

Storage Conditions

1) This product should be used within 12 months after delivered. Store in manufacturer's package keeping the seal of aluminum coated baggage or tightly re-closed box with the following conditions.
[Temperature: 8°C ... 30°C, Humidity: 30% ... 70% R.H.]

2) Keep the seal of aluminum coated baggage immediately before usage.

3) After breaking the seal of aluminum coated baggage, this product should be used within 1 week on the following conditions.
[Temperature: ≤ 30°C, Humidity: ≤ 60% R.H.]